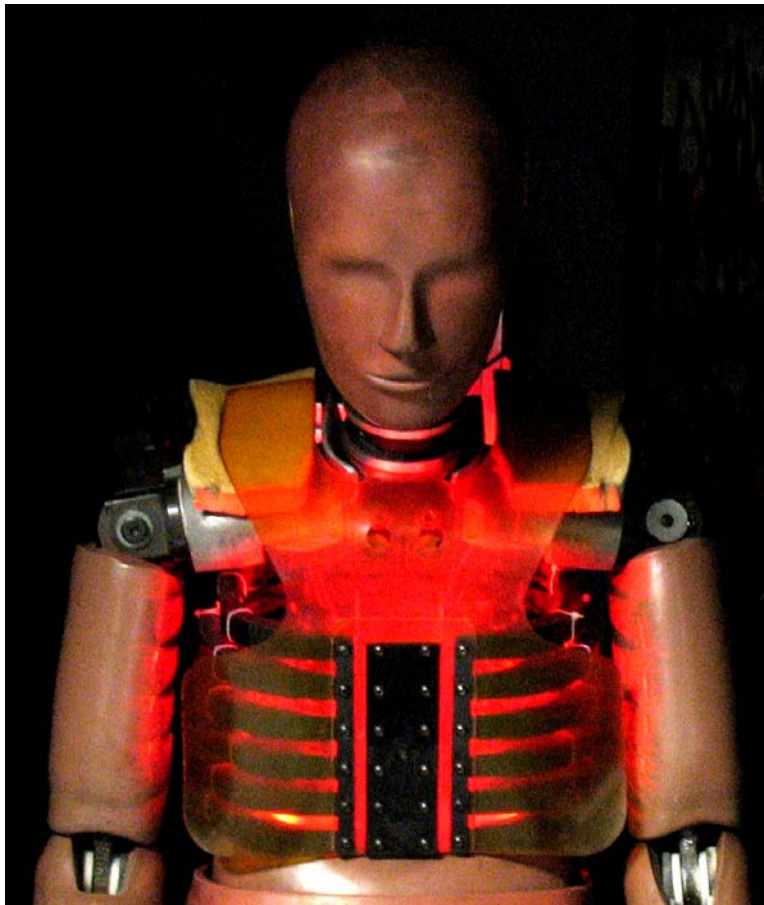




**HARDWARE USER'S MANUAL**  
**RibEye™ Multi-Point Deflection Measurement System**  
**for the Hybrid III ATD – 50<sup>th</sup> Male 2-Axis RibEye**



**Boxboro Systems LLC**  
**978-257-2219**  
**[www.boxborosystems.com](http://www.boxborosystems.com)**

## Table of Contents

	<u>Page</u>
<b>1.0 Overview</b> .....	5
<b>2.0 Mounting the RibEye</b> .....	10
2.1 Controller mounting.....	12
2.2 Installation and removal of the controller connector and cable .....	12
2.3 Sensor head mounting.....	18
2.4 LED mounting.....	18
Angled vs. flat LEDs .....	18
LED mounting procedure .....	19
2.5 LED connector block mounting.....	26
2.6 Interface/trunk box mounting.....	26
<b>3.0 Operating the RibEye</b> .....	28
3.1 Status light and manual arming.....	28
3.2 RibEye IP address .....	28
3.3 LED flashing on power up.....	28
<b>4.0 RibEye Software</b> .....	29
<b>5.0 RibEye Maintenance</b> .....	30
<b>Appendixes</b>	
A RibEye specifications.....	31
A.1 Accuracy and measurement range.....	31
A.2 Power requirements .....	36
A.3 Data acquisition and storage.....	36
B Cable assemblies .....	37
B.1 Controller cable.....	37
B.2 Power input cable .....	40
B.3 Trigger cable.....	42
B.4 LED cables .....	43
C Trigger inputs and armed output circuits .....	46

## List of Figures and Tables

<u>Figure No.</u>		<u>Page</u>
1	RibEye components.....	6
2	Front view of spine.....	7
3	Rear view of spine.....	8
4	Interface/trunk box .....	9
5	Interface/trunk box with cables .....	9
6	Diagram for mounting RibEye components.....	11
7	RibEye controller connector and cable .....	12
8	Install or remove screws that clamp the connector to the controller.....	13
9	Pull the connector out with the lanyard after removing screws .....	14
10	Pop the connector from its mate inside the controller using a screwdriver to lever the connector upward .....	15
11	Connector popped out of the controller and ready to be removed .....	16
12	Controller in back of spine after connector and cable have been removed.....	17
13	LED radiation pattern.....	18
14	Rib with double-stick foam tape in place .....	19
15	LED and angled mounting block.....	20
16	LED snapped into angled mounting block .....	20
17	Flat LED in place on rib with lead wire secured by nylon tie.....	21
18	Angled LED in place on rib with lead wire secured by nylon tie .....	21
19	Heat-shrink sleeve in place over flat LED .....	22
20	Heat-shrink sleeve in place over angled LED .....	22
21	Applying heat to shrink the sleeve and secure the LED tightly to the rib.....	23
22	Flat LED in place after heat-shrinking .....	24
23	Angled LED in place after heat-shrinking .....	24
24	Flat LED and lead wire installed.....	25
25	Angled LED and lead wire installed .....	25
26	LED connector blocks on RibEye sensor heads, rear view of spine .....	26
27	Interface/trunk box .....	27
A1	RibEye measurement range and typical accuracy, Rib 1 X axis .....	32
A2	RibEye measurement range and typical accuracy, Rib 1 Y axis .....	33
B1	RibEye controller cable and connector .....	37
B2	Controller cable, Souriau connector end details.....	38
B3	Controller cable, Microfit end details.....	39
B4	Power cable from RibEye trunk box .....	40
B5	Power cable details.....	41
B6	Trigger cable from RibEye trunk box .....	42
B7	Trigger cable details .....	43
B8	LED cables (lead wires) attached to connector blocks in RibEye sensor heads (rear spine view).....	44

## List of Figures and Tables, continued

<u>Figure No.</u>	<u>Page</u>
B9 LED cables, connector blocks, and sensor heads (front spine view) .....	44
B10 LED cable soldered to LED assembly .....	45
B11 LED cable, Microfit end details .....	45
C1 Partial interface schematic .....	47
C2 Tape switch or isolated contact closure for trigger .....	48
C3 Alternative tape switch or isolated contact closure for trigger .....	49
C4 Active trigger source .....	50
C5 Differential trigger source .....	50
C6 Armed output connection .....	51
<u>Table No.</u>	<u>Page</u>
A1 RibEye accuracy data (zero Z offset) .....	34
A2 RibEye accuracy data (Z offset of -10 mm) .....	34
A3 RibEye accuracy data (Z offset of +10 mm) .....	34
A4 RibEye accuracy data (Z offset of -20 mm) .....	35
A5 RibEye accuracy data (Z offset of +20 mm) .....	35
A6 RibEye power requirements .....	36
C1 Trigger cable signals .....	46

**HARDWARE USER'S MANUAL**  
**RibEye™ Multi-Point Deflection Measurement System**  
**for the Hybrid III ATD – 50<sup>th</sup> Male 2-Axis RibEye**

## **1.0 Overview**

The RibEye measurement system as designed for this ATD (anthropomorphic test dummy) has the following components, shown in Figure 1:

- Two sets of six LEDs (total of 12) that are mounted on the ribs
- Two optical sensor heads that derive the position of the LEDs during RibEye operation
- Two LED connector blocks that are built into the sensor heads
- The RibEye controller, which is mounted inside the back of the spine
- The interface box, also called the trunk box because it is usually placed in the trunk of the vehicle.

Appendix A provides detailed specifications for the RibEye, including accuracy, measurement range, and power requirements.

**Figure 1. RibEye components**

A = LEDs; B = sensor heads; C = LED connector blocks; D = controller; E = spine; F = interface/trunk box



Figures 2 and 3 show the sensor heads, LED connector blocks, and controller location in greater detail. The interface/trunk box has sockets for the RibEye controller, power input, and trigger cables (Figures 4 and 5). Appendix B contains more information on cable assemblies.

**Figure 2. Front view of spine**  
A = sensor heads; B = LED connector blocks



**Figure 3. Rear view of spine**  
A = controller; B = controller mounting screws;  
C = RibEye controller connector and cable to trunk box;  
D = controller connector screws; E = LED connector blocks

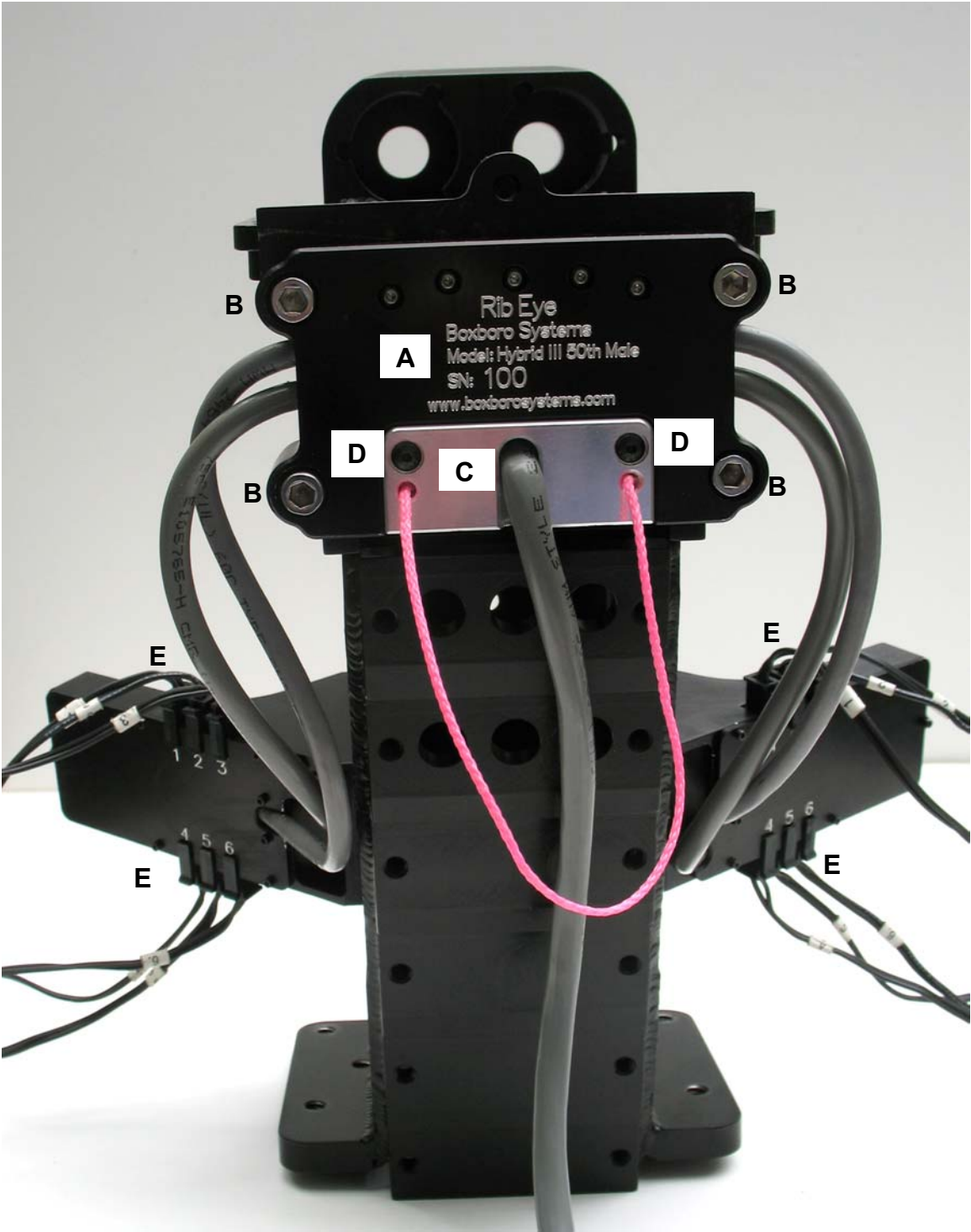
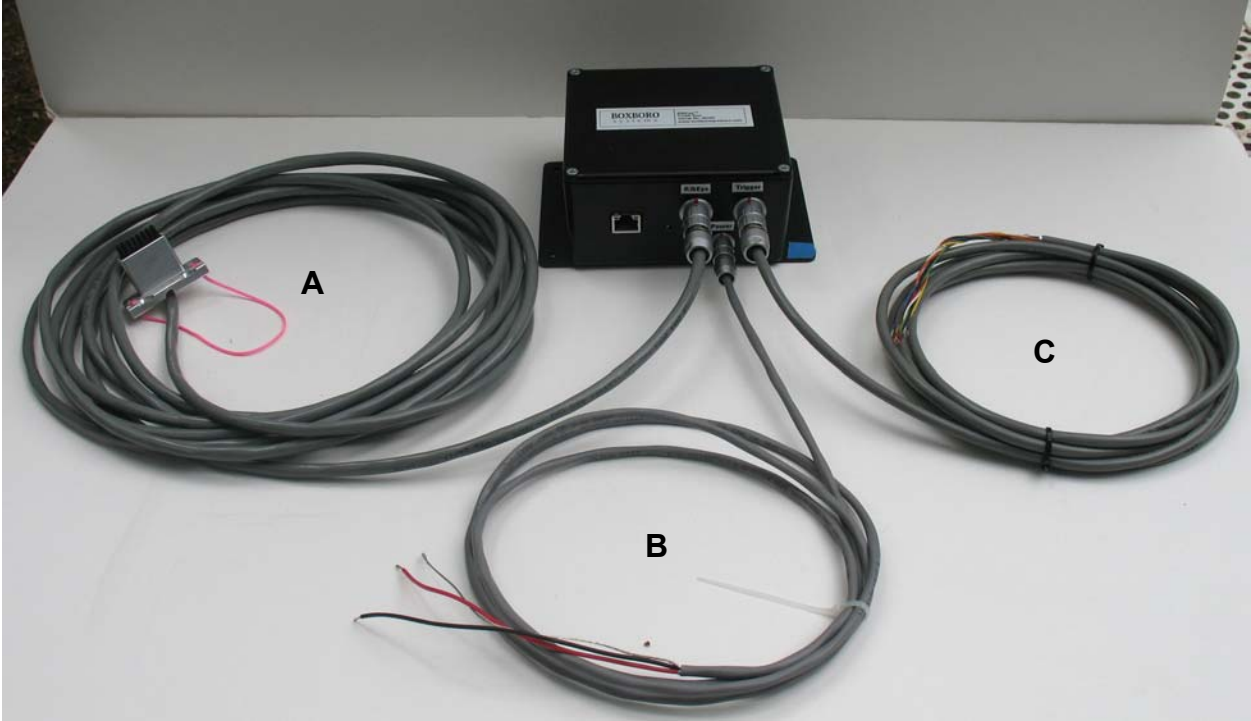


Figure 4. Interface/trunk box



Figure 5. Interface/trunk box with cables  
A = RibEye controller; B = power; C = trigger

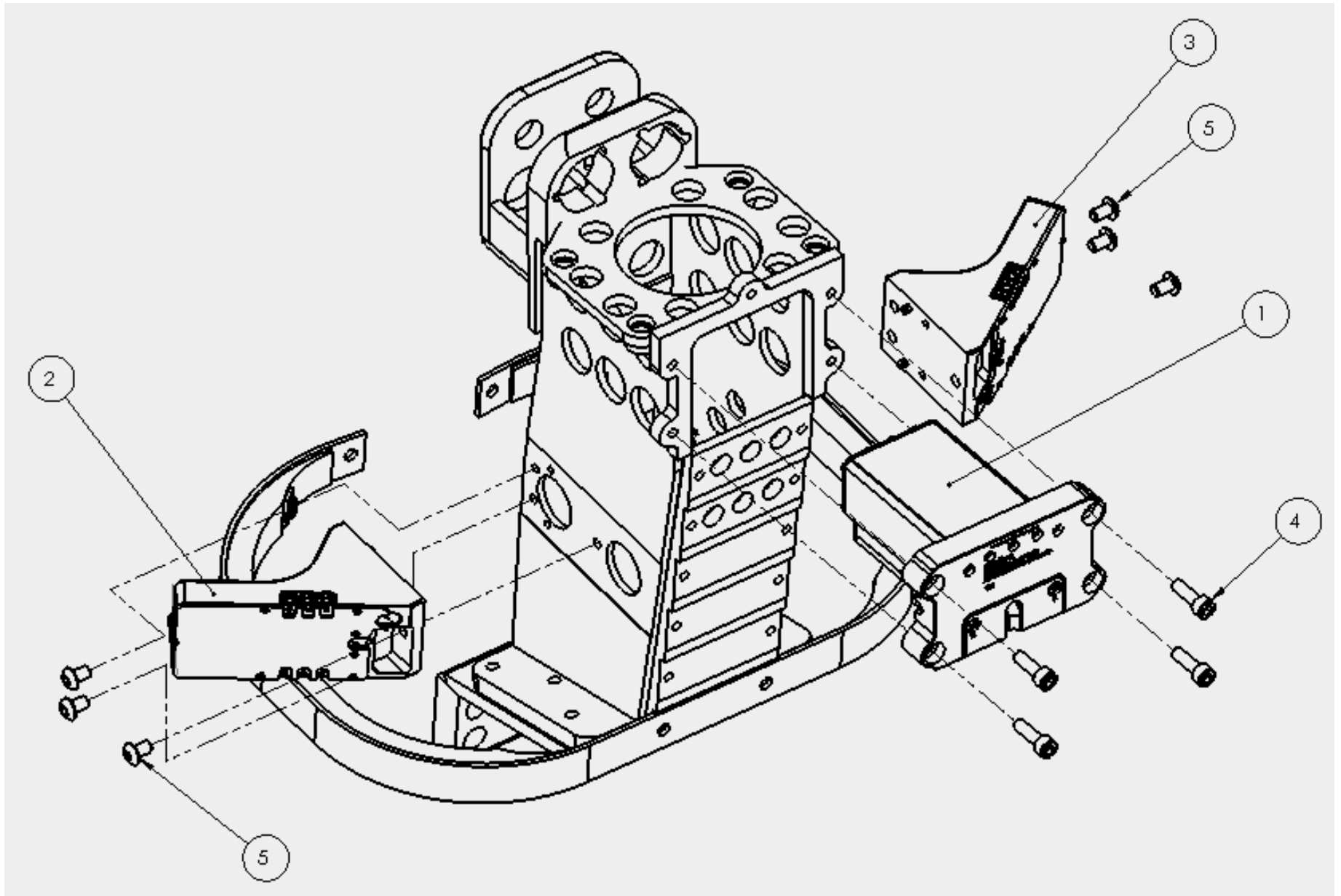


## **2.0 Mounting the RibEye**

A diagram for mounting the RibEye controller and sensor heads is shown in Figure 6. The controller and sensor heads should be mounted to the dummy's spine before assembling the ribs onto the spine. The following mounting instructions are specific to the 50<sup>th</sup> Male 2-axis RibEye for the Hybrid III ATD.

**Figure 6. Diagram for mounting RibEye components**

1 = controller; 2 = left sensor head; 3 = right sensor head; 4 = four screws for mounting controller (socket head cap #10-32 x 5/8);  
5 = six screws for mounting sensor heads (button head cap #10-32 x 5/16)



## 2.1 Controller mounting

The controller slides into the back of the spine and is attached with four screws (see Figure 3-B and Figure 6).

## 2.2 Installation and removal of the controller connector and cable

The RibEye controller connector (Figure 7) plugs into the back of the controller and is kept in place by two #4-40 x 5/8 button-head cap screws (Figure 3-D). The communications cable runs out of the controller and then down under the dummy skin (jacket) to exit at the bottom of the dummy skin. The cable is routed to the interface/trunk box.

**Figure 7. RibEye controller connector and cable**



To install the controller cable, insert the connector into the controller and use an Allen wrench to tighten the two #4-40 screws, as shown in Figure 8.

To remove the connector and cable after a test, first remove the screws, then pull on the pink lanyard, as shown in Figure 9. This will pop the connector out from its mating connection inside the controller.

Alternatively, you can use a flat-head screwdriver to pop the connector out. Insert the screwdriver into the slots on the bottom of the connector as shown in Figure 10. Then twist the screwdriver to lever the connector out (Figure 11).

After the connector has been popped out, it can be pulled out of the controller safely. **DO NOT PULL ON THE CABLE ITSELF.** Figure 12 shows the back of the spine with the controller connector and cable removed.

Figure 8. Install or remove screws that clamp the connector to the controller

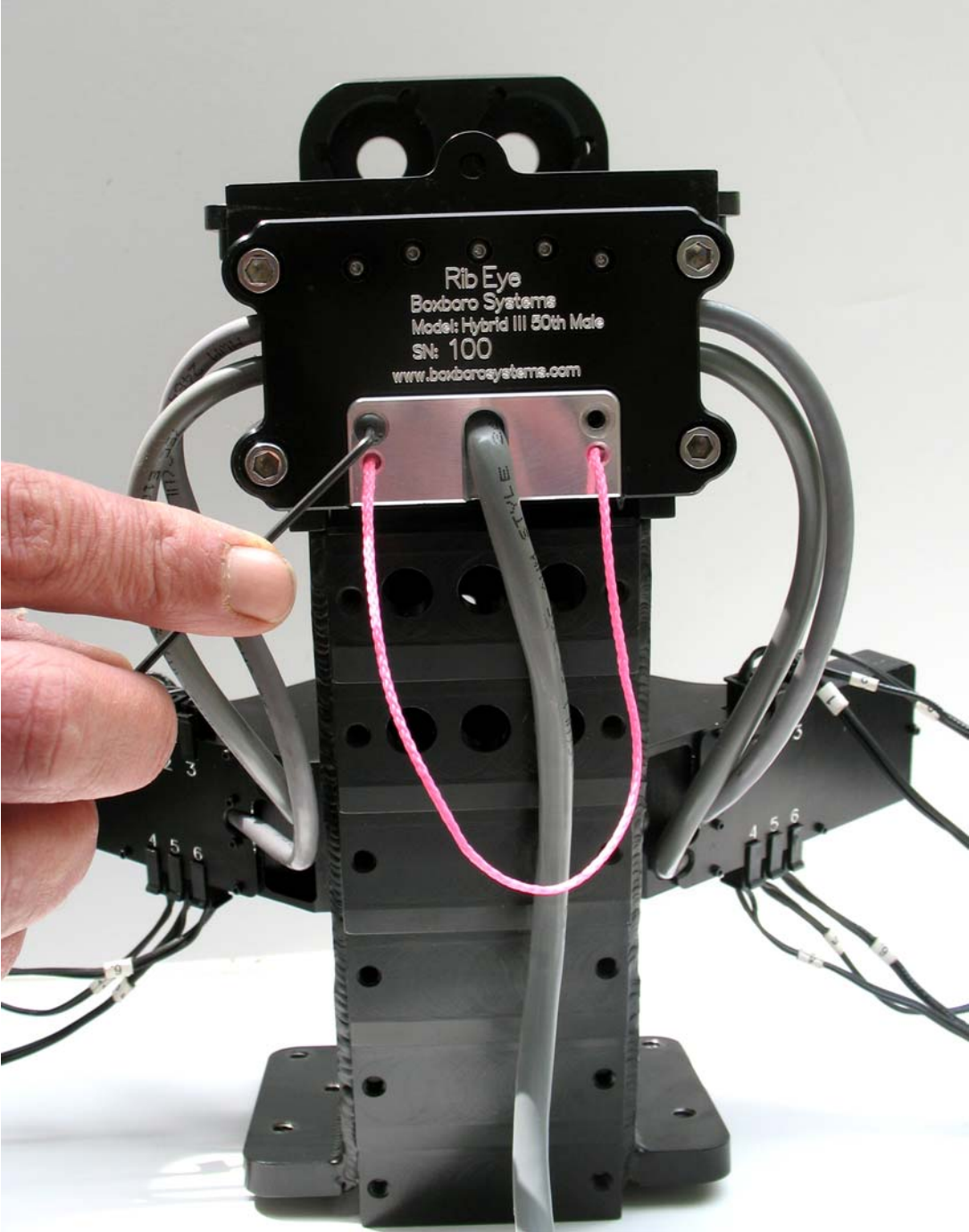
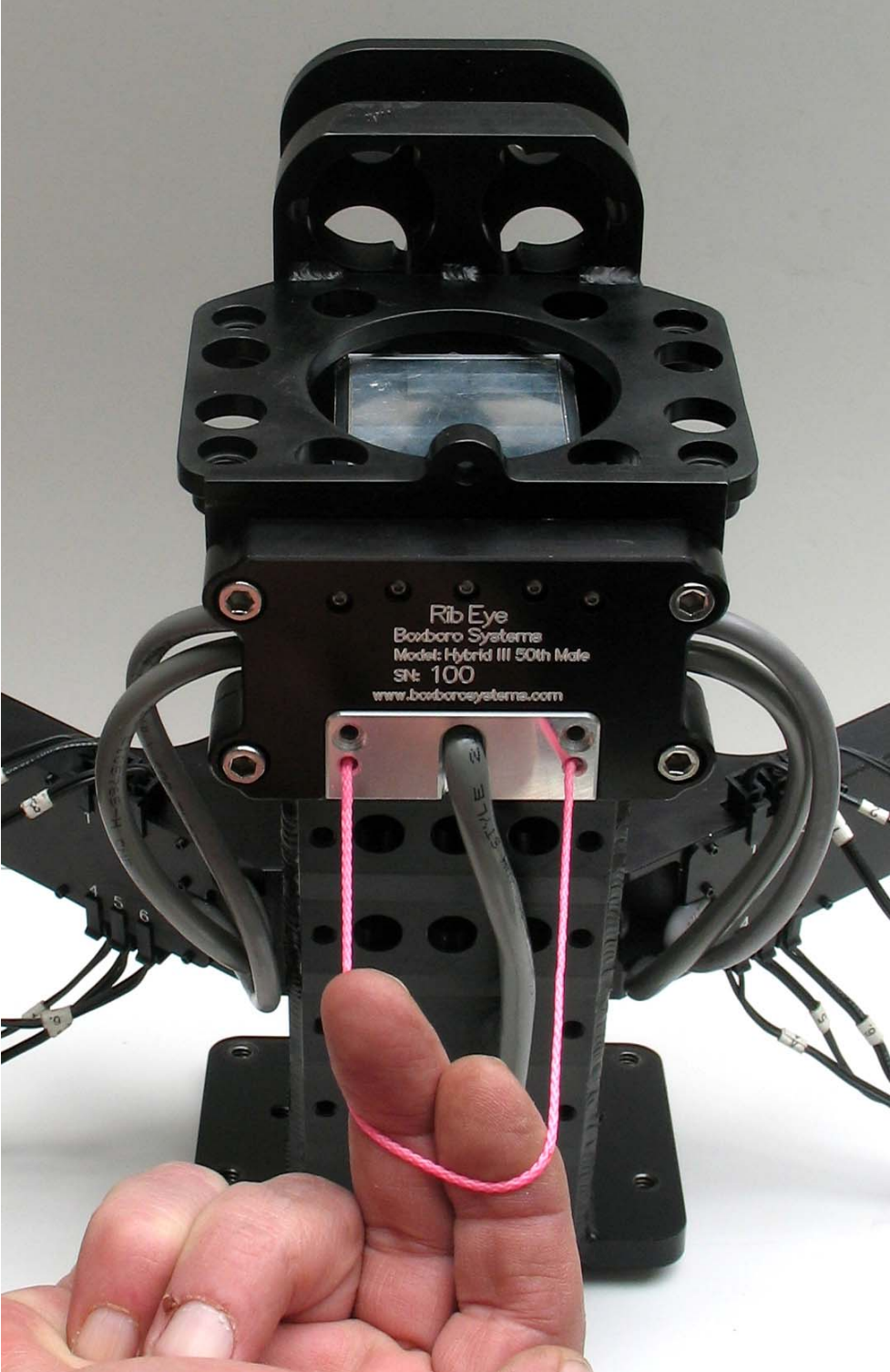


Figure 9. Pull the connector out with the lanyard after removing screws



**Figure 10. Pop the connector from its mate inside the controller using a screwdriver to lever the connector upward**

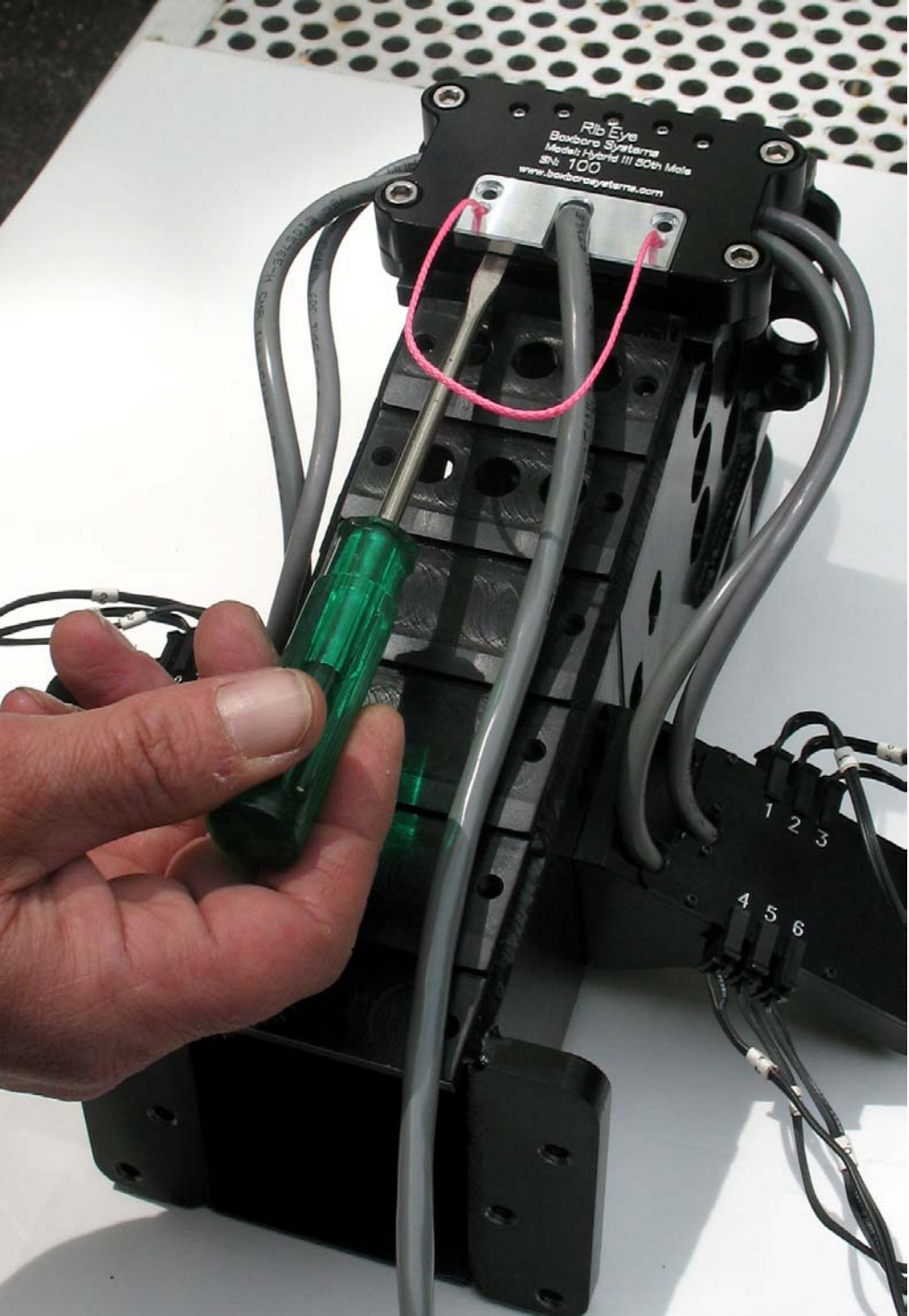


Figure 11. Connector popped out of the controller and ready to be removed

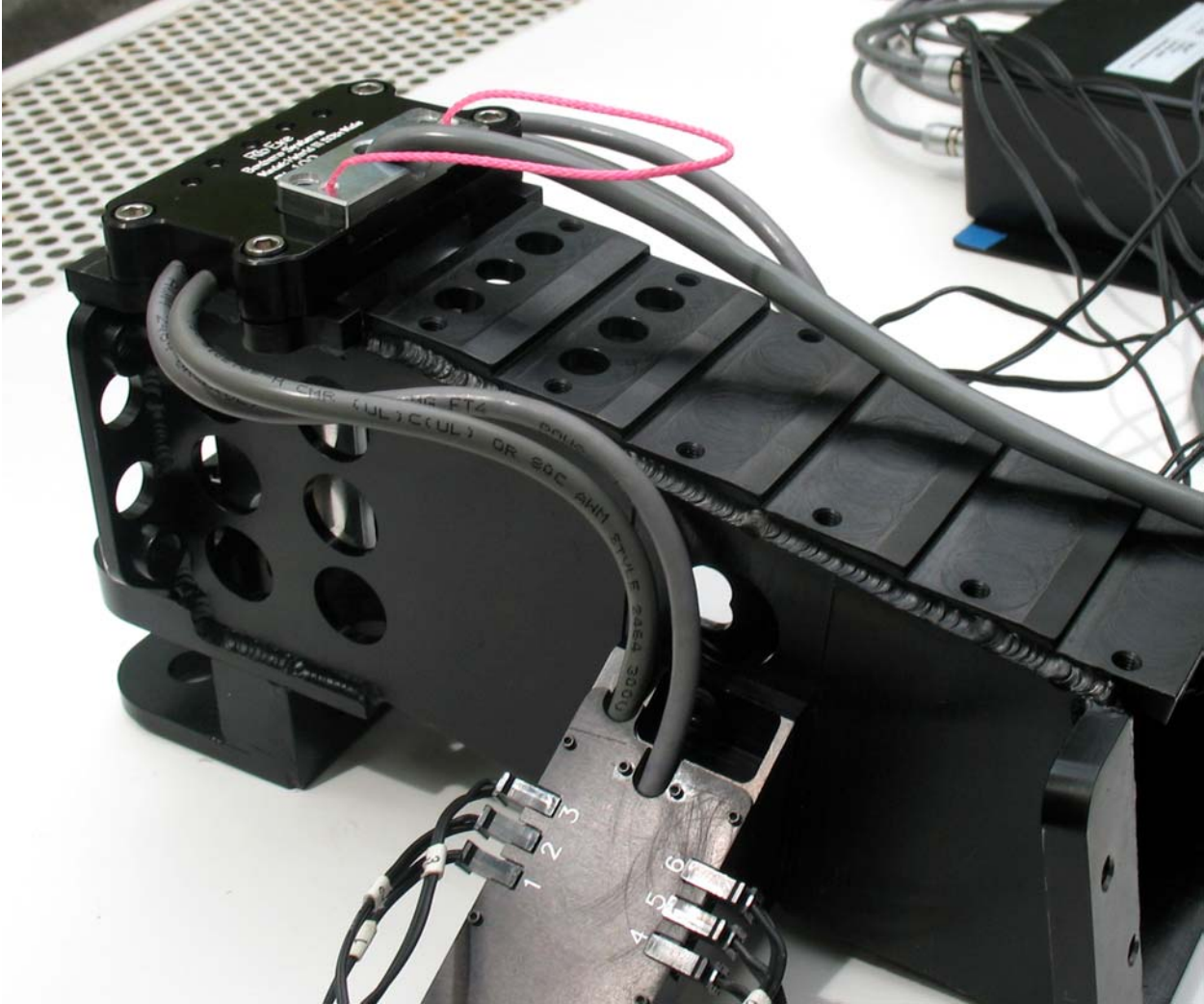
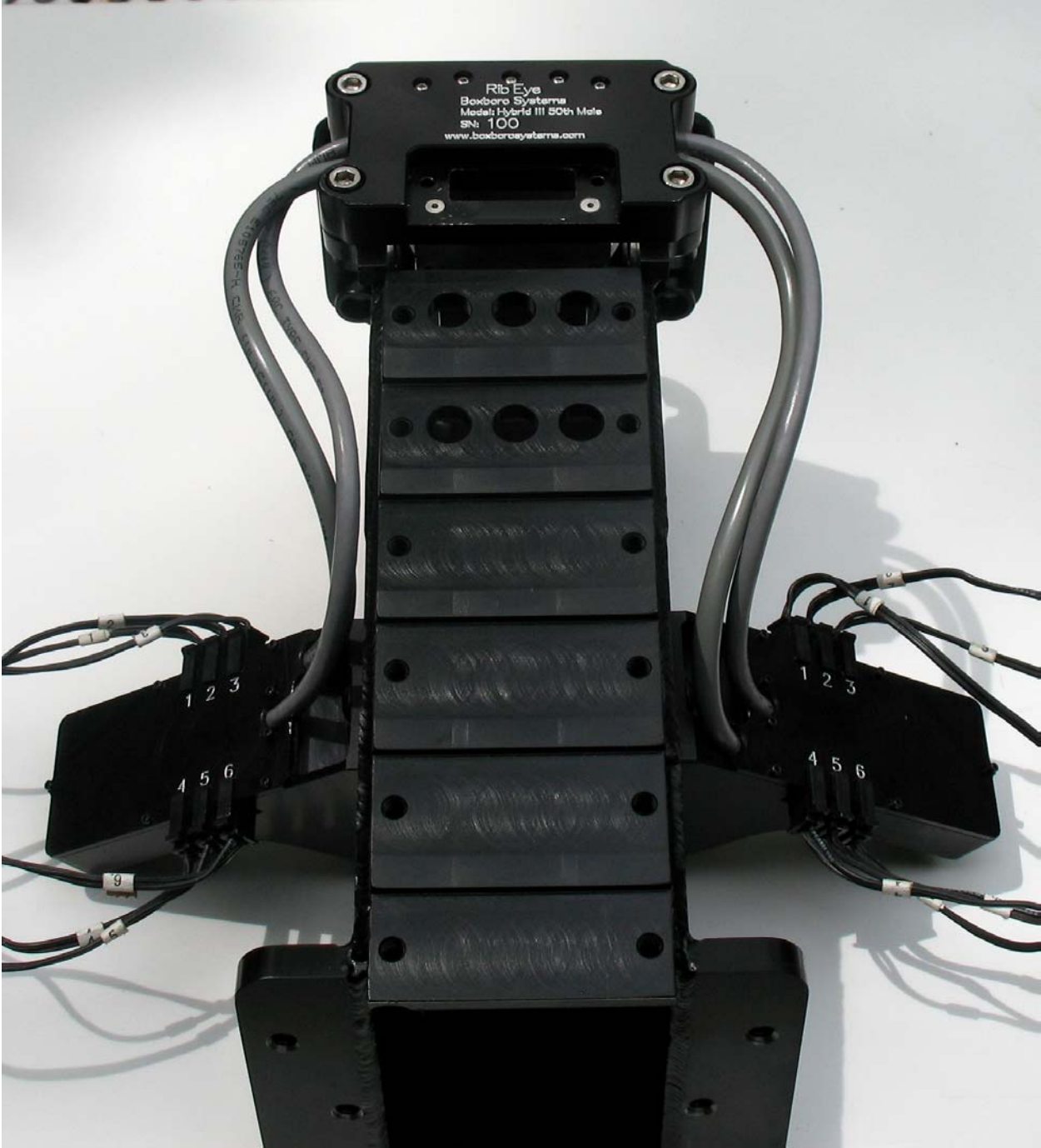


Figure 12. Controller in back of spine after connector and cable have been removed



### 2.3 Sensor head mounting

The two optical sensor heads are mounted to the left and right sides of the spine. Each sensor head is attached to the spine with three screws, as shown in Figure 6. Note that the spine has alignment pins that fit into precision holes in the sensor heads. The sensor heads also contain built-in connector blocks for the LED cables to plug into. Section 2.5 and Appendix B.4 provide more details on the LED connector blocks and cables.

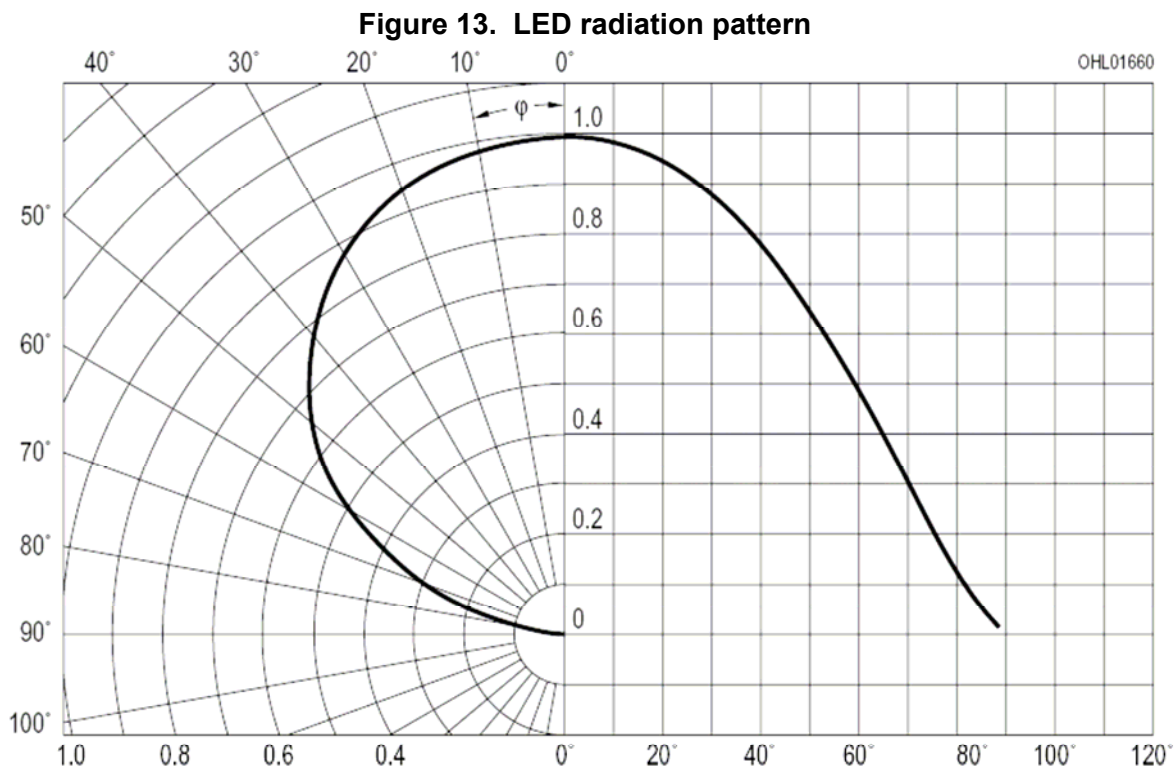
### 2.4 LED mounting

The LEDs should be mounted to the ribs before the ribs are assembled onto the spine. The top rib is Rib 1, and the bottom rib is Rib 6. Left and right refer to the dummy's left and right sides. The LED cables and connector blocks are marked 1–6 for Ribs 1–6. **DANGER:** *The LEDs are very bright when driven at full power. Never look directly at the LEDs when they're turned on.*

#### Angled vs. flat LEDs

Some of the LEDs have an angled mounting surface that aims the LED toward the sensor head to provide the maximum amount of light to the sensors while minimizing power requirements. The LEDs on Ribs 3 and 4 are installed flat, directly onto the rib surface. The LEDs on Ribs 1, 2, 5, and 6 are mounted on angled blocks, which are then installed on the rib surface.

Figure 13 shows the radiation pattern of the LEDs, which explains why angling them improves their performance. Note that the brightest light is directly in front of the LED (on axis), and the brightness gets lower at larger angles. The RibEye controller continuously adjusts how hard it drives the LEDs to get a good signal to the sensors.



The RibEye uses different calibration curves to process the LED data, depending on which rib that the LED is mounted on (that is, its Z-axis location up or down). To obtain the guaranteed accuracy, the LEDs should be plugged into the connectors numbered for the rib they are attached to. The LED on Rib 1 plugs into connector #1, the LED on Rib 2 plugs into connector #2, etc.

If the light from a LED to a sensor head is blocked, the position reading will be invalid. If the dummy instrumentation uses a chest potentiometer, the chest pot arm can often block light from the LEDs to the sensors, causing error codes. If you need to run a test with a chest pot, we recommend that the arm be painted flat black to minimize reflections. The test operator can also adjust the positions of the LEDs on the ribs to minimize blockage from a chest pot arm. Please see section 4.0 below for more information on error codes.

### **LED mounting procedure**

For best performance, the LEDs should be mounted  $\pm 70$  mm in the dummy Y direction from the centerline of the sternum, or approximately 90 mm along the curve of the ribs from the centerline of the sternum. This places the LEDs near the tip of the rib, just before the rib thickness increases.

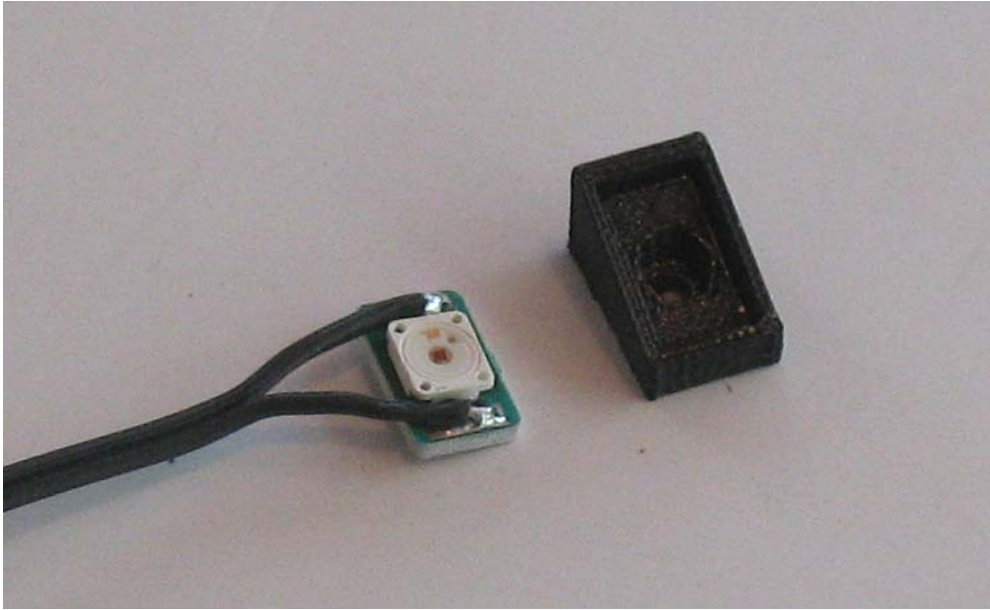
To begin mounting the LEDs, first cut two pieces of double-stick foam tape, each about 8-10 mm long. Stick the tape to the rib just inside of the thick portion (Figure 14). Peel off the paper on the other side, leaving a sticky surface prepared for the LEDs. Double-stick foam tape is supplied in the RibEye package.

**Figure 14. Rib with double-stick foam tape in place**

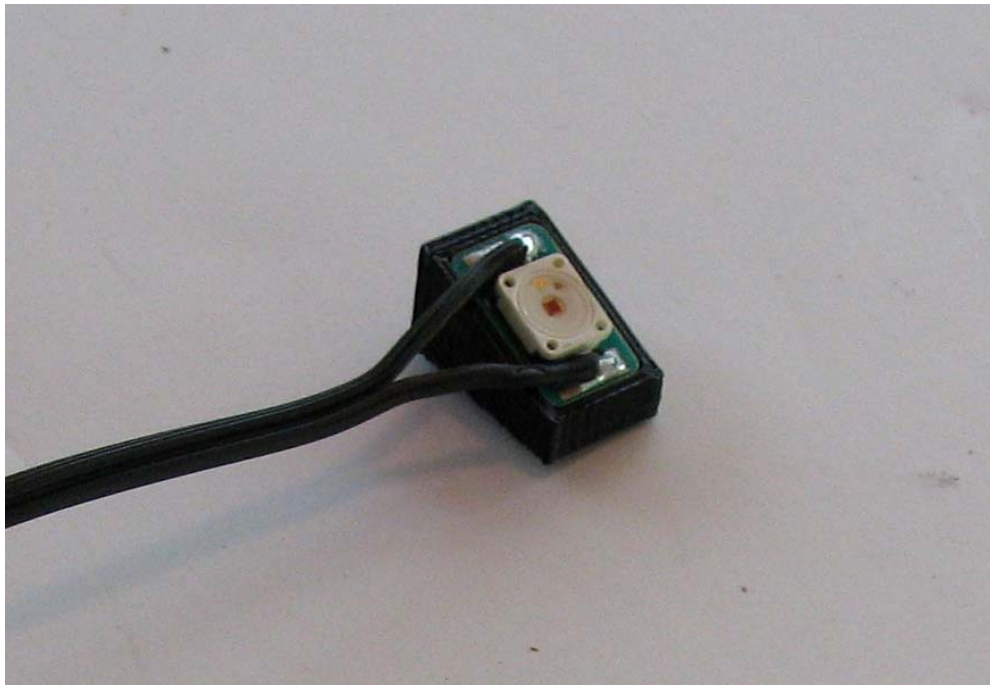


As noted earlier, the LEDs on Ribs 3 and 4 are installed flat, directly onto the rib surface. The LEDs on Ribs 1, 2, 5, and 6 are mounted on angled blocks, which are then installed on the rib surface. For flat-mounted LEDs, apply the LED directly to the sticky tape. For angle-mounted LEDs, first snap the LED into the mounting block (Figures 15 and 16), then apply the block to the sticky tape on the rib. Tightly secure the LEDs' lead wires to the ribs using nylon ties. Figures 17 and 18 show flat and angled LEDs stuck to the ribs.

**Figure 15. LED and angled mounting block**



**Figure 16. LED snapped into angled mounting block**



**Figure 17. Flat LED in place on rib with lead wire secured by nylon tie**



**Figure 18. Angled LED in place on rib with lead wire secured by nylon tie**



Next, slide a heat-shrink sleeve over the LED, centering the hole directly over the red dot in the center of the LED (Figures 19 and 20). The heat-shrink sleeves are included in the RibEye package. The heat-shrink tubing is standard 1-inch-diameter polyolefin with a 3:1 shrink ratio and a shrink temperature of 100°C (212°F). **NOTE:** *Do not use glue-lined heat-shrink tubing because the glue can bubble out of the LED hole and get on the front of the LED.*

**Figure 19. Heat-shrink sleeve in place over flat LED**

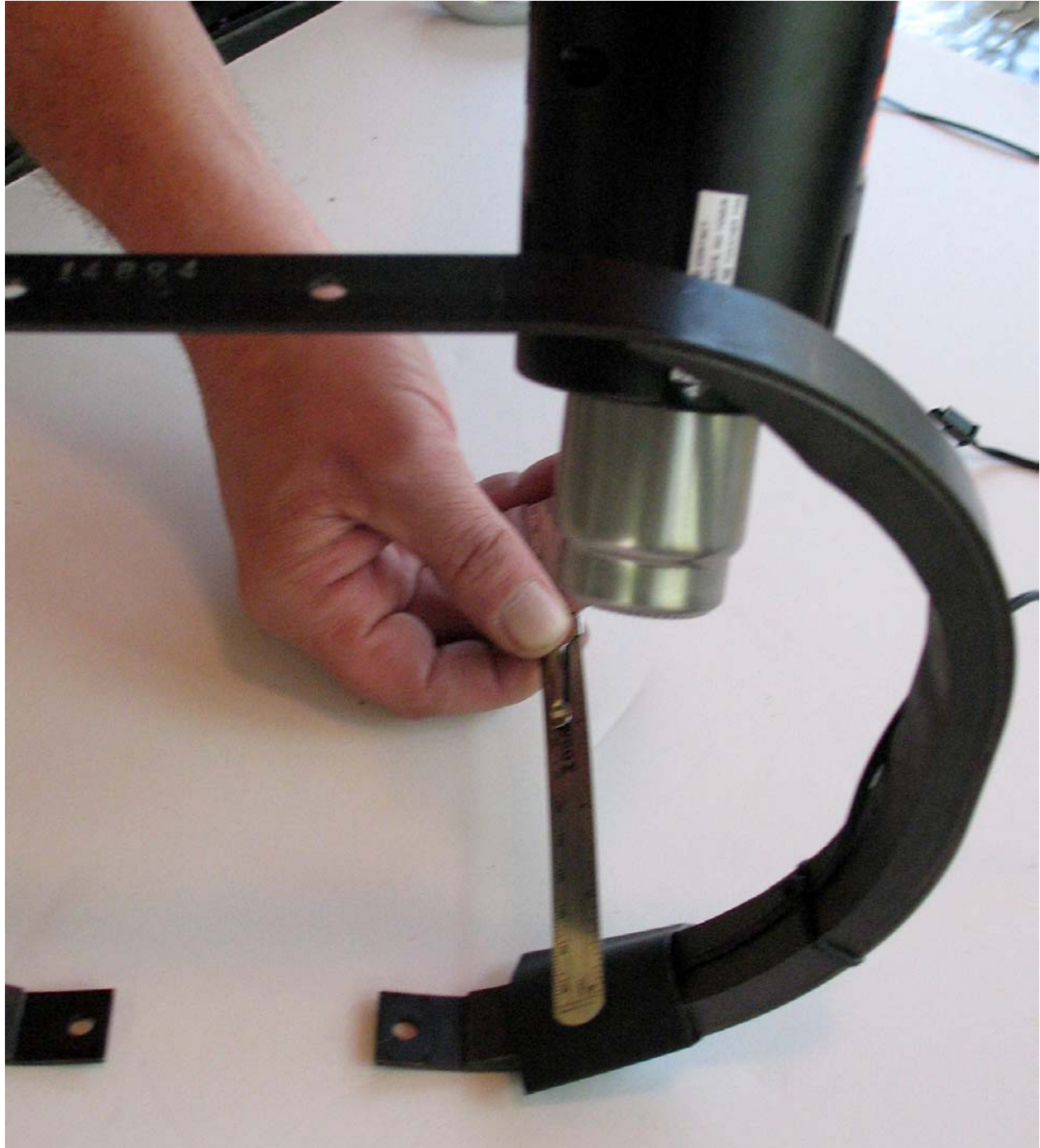


**Figure 20. Heat-shrink sleeve in place over angled LED**



When the heat-shrink sleeves are positioned, use a heat gun to apply heat to the front of the sleeve while shielding the LED with a flat metal device such as a ruler (Figure 21), then apply heat to the back of the sleeve. For a tight fit, be sure to eliminate bubbles in the sleeve material.

**Figure 21. Applying heat to shrink the sleeve and secure the LED tightly to the rib**



Return to the front of the sleeve and apply heat gently without shielding the LED. Stretch the round hole with your finger so that it fits around the square edge of the LED. It need not be perfectly aligned, but extra materials are supplied in case your first attempt is unsuccessful. Figures 22 and 23 show flat and angled LEDs after heat-shrinking. Figures 24 and 25 show the ribs with installed LEDs and lead wires.

**Figure 22. Flat LED in place after heat-shrinking**



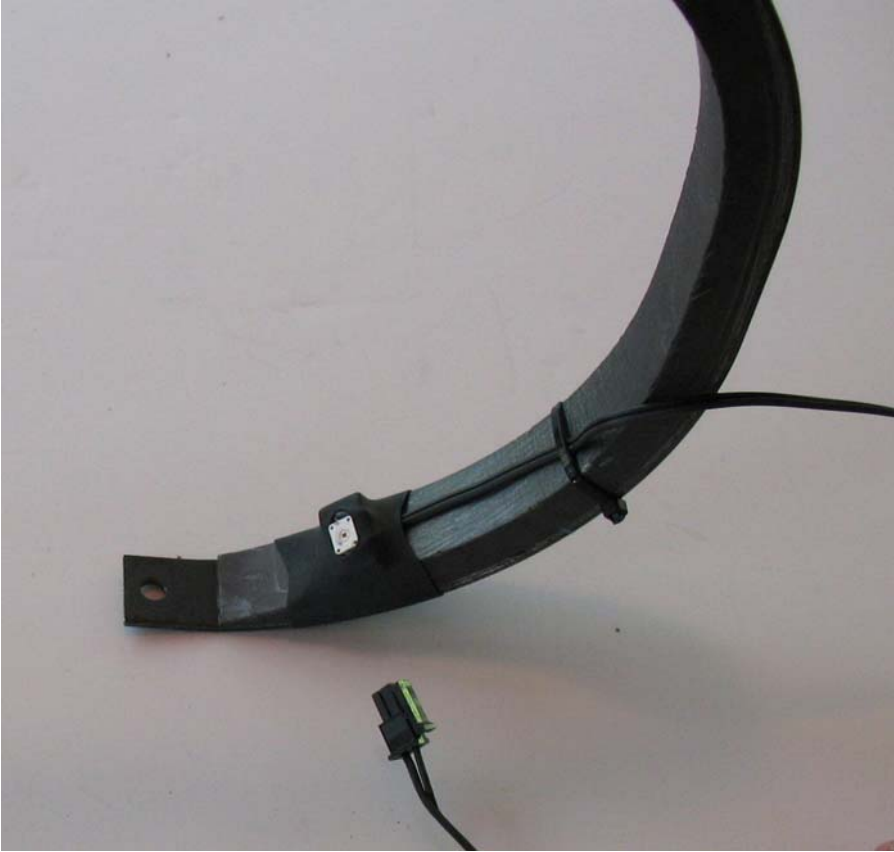
**Figure 23. Angled LED in place after heat-shrinking**



**Figure 24. Flat LED and lead wire installed**



**Figure 25. Angled LED and lead wire installed**



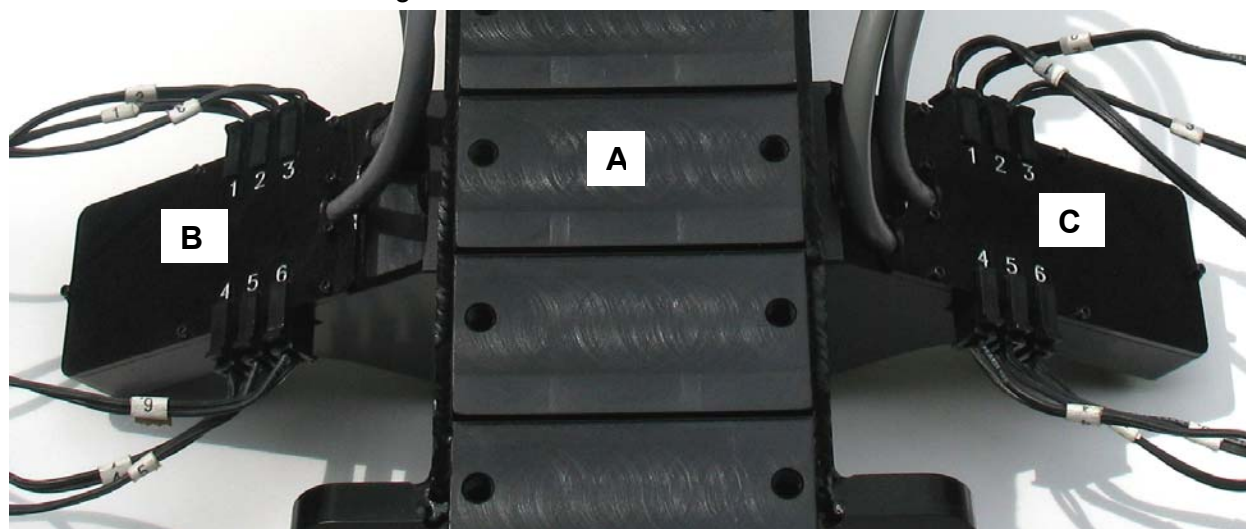
## 2.5 LED connector block mounting

Once the LEDs are in place and their lead wires (cables) secured tightly to the ribs, the ribs can be assembled onto the dummy spine, and the other end of the LED cables can be plugged into the LED connector blocks on the rear side of the RibEye sensor heads. The connections are marked with numbers that correspond to the rib numbers, 1–6, left and right (Figure 26). Appendix B provides more detail on the LED cable assemblies.

**NOTE:** *All loose LED lead wires/cables must be gathered and restrained to prevent them from entering the sensors' field of view and blocking the light between the LEDs and the sensors. This causes error codes, as described above for chest pot arms. See section 4.0, RibEye software, for more information on error codes.*

**Figure 26. LED connector blocks on RibEye sensor heads, rear view of spine**

A = spine (rear); B = left LED connector block and sensor head;  
C = right LED connector block and sensor head



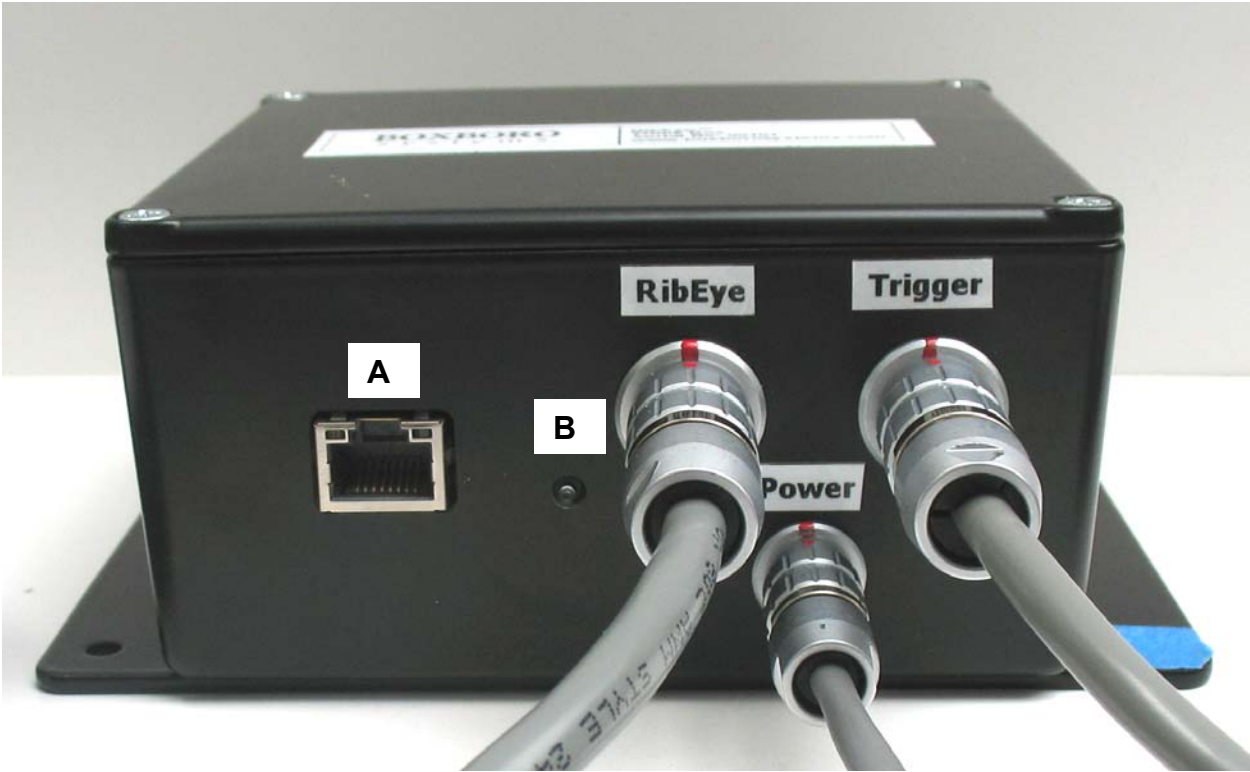
## 2.6 Interface/trunk box mounting

The interface/trunk box is intended to be mounted in the trunk of the vehicle, near the power source. Four holes are provided on the base of the box for mounting. The trunk box can be mounted in any orientation, but we recommend that it be mounted such that the side of the box with all of the connectors is easily accessible.

The RibEye communications cable from the controller in the spine is connected to the jack on the trunk box labeled “RibEye” (Figure 27). Jacks and pigtail cables are also provided for incoming power and trigger connections. The power cable should be connected to a DC power source. Appendix A.2 lists the RibEye’s power requirements, and Appendix B provides details on all cable assemblies).

The trigger cable is used to provide a trigger input to the RibEye. Appendix C contains the trigger connector pinouts and trigger circuits. An Ethernet cable is used to connect the trunk box either to a router/hub or directly to a laptop PC. The status light indicates whether the RibEye is idle or busy acquiring data (see section 3.1, Status light and manual arming).

**Figure 27. Interface/trunk box**  
A = Ethernet connection; B = status light



### 3.0 Operating the RibEye

The RibEye operates as a stand-alone smart sensor that acquires and stores data. A PC program is used to control the RibEye, download data, and export data in standard formats. Please refer to the RibEye Software User's Manual for details on how the PC program functions. This software manual is included on a disk with the RibEye package, or you can access it on our website at <http://www.boxborosystems.com/servicepage.html>. Updates to the RibEye PC software can be downloaded from the website as they become available.

The RibEye has a published control protocol, and some manufacturers of data acquisition systems have added RibEye control to their DAS software. Please contact Boxboro Systems for more information.

#### 3.1 Status light and manual arming

The status light on the interface/trunk box blinks at different rates depending on what the RibEye is doing:

- 0.5 Hz = idle with data in memory
- 1.0 Hz = idle with memory erased
- 2.0 Hz = acquiring data
- 5.0 Hz = storing data in flash memory
- 10 Hz = erasing flash memory

The status light also functions as a push-button that can be used to manually arm the RibEye when it is idle and the memory is erased. To manually arm the RibEye, you must hold the status light button pushed down for at least 3 seconds.

#### 3.2 RibEye IP address

The RibEye ships from the factory with its IP address set to 192.168.0.240. This IP address can be changed to work with your LAN (local area network). Alternatively, you can communicate with the RibEye directly using a PC, without connecting to a LAN. To connect a PC directly to the RibEye, your PC must be set up with a fixed IP address on the same subnet as the RibEye. For instructions on how to change the RibEye IP address, please refer to the RibEye Software User's Manual, Appendixes A-C.

#### 3.3 LED flashing on power up

When the RibEye is powered on, it will flash each LED for about 1 second. The LEDs will flash in the following order:

1. Rib 1 Left
2. Rib 2 Left
3. Rib 3 Left
4. Rib 4 Left
5. Rib 5 Left
6. Rib 6 Left
7. Rib 1 Right
8. Rib 2 Right
9. Rib 3 Right
10. Rib 4 Right
11. Rib 5 Right
12. Rib 6 Right

## 4.0 RibEye Software

For instructions on how to install and operate the RibEye's PC software, please refer to the latest version of our Software User's Manual. As noted above, this software manual is included on a disk with the RibEye package, or you can access it on our website at <http://www.boxborosystems.com/servicepage.html>. Updates to the RibEye PC software can be downloaded from the website as they become available.

If the RibEye cannot accurately calculate a LED position, it will generate error codes in the data file, causing a drop-out in the plots. The RibEye will force the X and Y data to the same error code. The error codes are generated when light from a LED is blocked between the LED and one of the sensors, or when there is too much ambient light to accurately resolve the LED position.

For two-axis systems, the X and Y data will be forced to –

- 1 if the left sensor (dummy's left) is blocked or sees too much ambient light
- 2 if the right sensor (dummy's right) is blocked or sees too much ambient light
- 3 if both sensors are blocked or see too much ambient light
- 327 if a divide-by-zero condition occurred in the data processing

If an error code occurs, you need to discount the data for a few milliseconds before and after the drop-out, because the LED brightness control loops must stabilize. Most often, the cause of a drop-out is a loose cable that swings between the LED and the sensors, blocking the light, or a chest pot arm as noted above in section 2.4. Error conditions can also occur if the rib rotates enough so that the light from the LED cannot reach the sensor.

Note that the error codes can get masked by filtering the data. Also, removing the zero offsets will change the error levels by the zero offset amount, and all three axes will no longer be at the same level. Therefore we strongly recommend reviewing and saving a copy of the unfiltered, absolute data so that the error codes are preserved.

## 5.0 RibEye Maintenance

The RibEye lenses must be kept very clean for accurate measurements. Dust and smudges from fingers will affect the RibEye's accuracy detrimentally.

Follow this procedure for cleaning the lenses:

1. Blow the lenses off with canned compressed air (*not* shop air) to remove any grit
2. Wipe the lenses with a *dry*, clean, lint-free cloth, or wipe the lenses with a clean, lint-free cloth and lens-cleaning solution or alcohol

There are **NO** user-serviceable parts in the RibEye.

## **Appendix A. RibEye specifications**

### **A.1 Accuracy and measurement range**

The RibEye's accuracy is specified in the calibration report that is shipped with each unit. The measurement range and typical accuracy of the RibEye in the X-Y plane are shown in Figures A1 and A2 for Rib 1. This data is from a calibration report.

Figure A1. RibEye measurement range and typical accuracy, Rib 1 X axis (calibration report data)

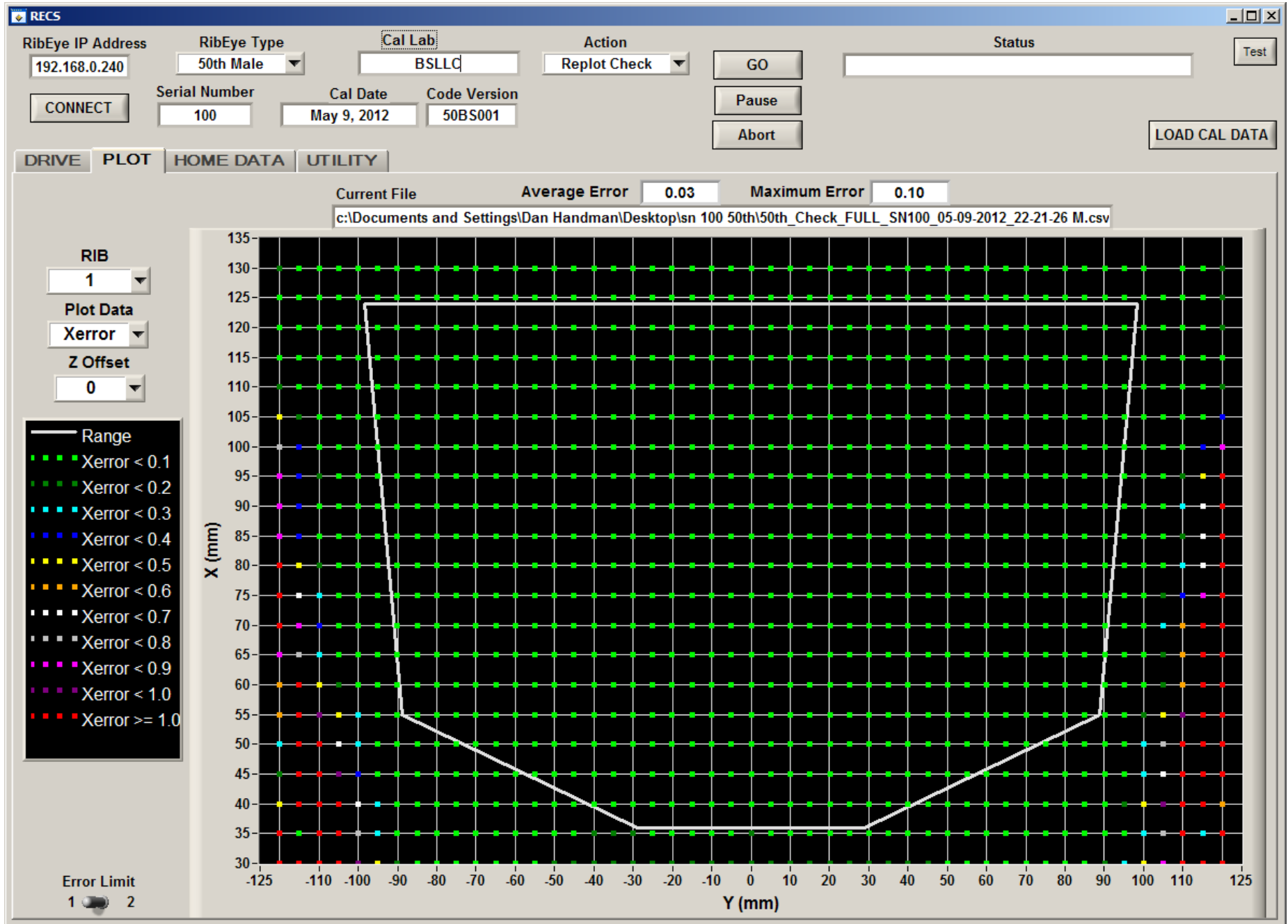
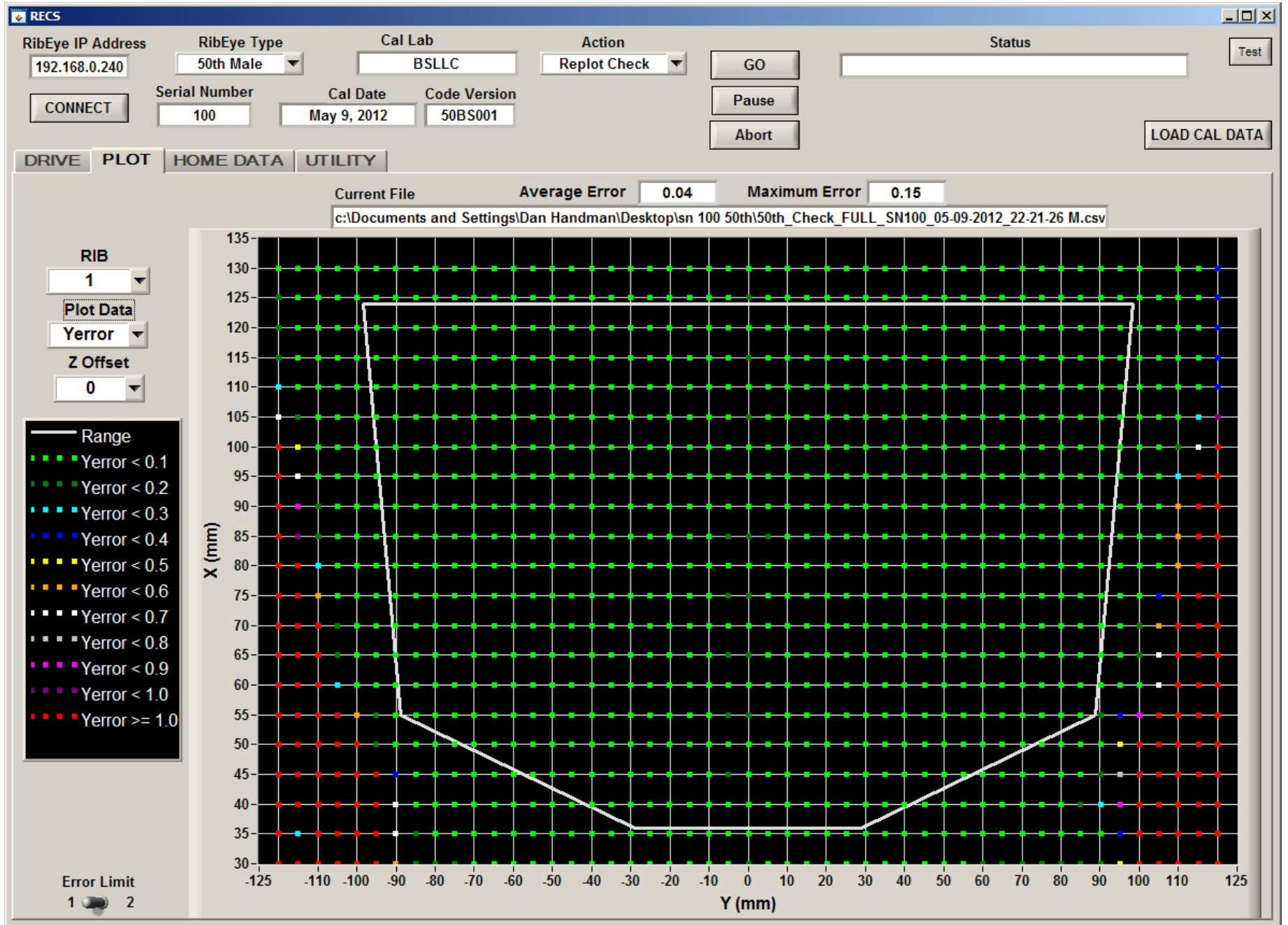


Figure A2. RibEye measurement range and typical accuracy, Rib 1 Y axis (calibration report data)



The accuracy of the RibEye depends on the Z (up and down) position of the ribs. The RibEye's accuracy over its measurement range is specified in the calibration report that is shipped with each unit. Table A1 shows the accuracies measured over the entire range for each rib at a Z offset of zero (nominal rib position with no Z axis deflection). Tables A2–A5 show accuracy data for Z offsets of  $\pm 10$  mm and  $\pm 20$  mm. All of this data is from a calibration report.

**Table A1. RibEye accuracy data (zero Z offset)**

Rib number	X error		Y error	
	mm			
	Max.	Avg.	Max.	Avg.
1 (top)	0.10	0.03	0.15	0.04
2	0.09	0.04	0.10	0.04
3	0.29	0.02	0.85	0.06
4	0.11	0.02	0.31	0.04
5	0.09	0.02	0.21	0.03
6 (bottom)	0.07	0.02	0.11	0.03

**Table A2. RibEye accuracy data  
(Z offset of  $-10$  mm)**

Rib number	X error		Y error	
	mm			
	Max.	Avg.	Max.	Avg.
1 (top)	0.52	0.16	0.48	0.20
2	0.35	0.11	0.38	0.19
3	0.43	0.06	0.97	0.18
4	0.24	0.04	0.47	0.14
5	0.26	0.07	0.40	0.18
6 (bottom)	0.33	0.13	0.50	0.18

**Table A3. RibEye accuracy data  
(Z offset of  $+10$  mm)**

Rib number	X error		Y error	
	mm			
	Max.	Avg.	Max.	Avg.
1 (top)	0.30	0.15	0.37	0.17
2	0.24	0.10	0.42	0.13
3	0.47	0.05	1.28	0.11
4	0.25	0.05	0.35	0.12
5	0.42	0.13	0.43	0.17
6 (bottom)	0.49	0.18	0.47	0.19

**Table A4. RibEye accuracy data  
(Z offset of -20 mm)**

Rib number	X error		Y error	
	mm			
	Max.	Avg.	Max.	Avg.
1 (top)	0.89	0.32	0.91	0.39
2	0.69	0.24	0.74	0.36
3	0.64	0.11	1.25	0.31
4	0.44	0.05	0.75	0.27
5	0.32	0.09	0.76	0.33
6 (bottom)	0.61	0.23	0.90	0.35

**Table A5. RibEye accuracy data  
(Z offset of +20 mm)**

Rib number	X error		Y error	
	mm			
	Max.	Avg.	Max.	Avg.
1 (top)	0.55	0.25	0.68	0.34
2	0.30	0.13	0.59	0.26
3	0.29	0.05	1.94	0.22
4	0.47	0.11	0.75	0.27
5	0.79	0.27	0.84	0.34
6 (bottom)	0.95	0.37	0.92	0.38

## A.2 Power requirements

The RibEye can be powered by any DC power source from 12 to 36 Volts. The power cable from the RibEye's interface/trunk box to the power source has two conductors: the red wire is positive, and the black wire is negative (ground). Appendix B.2 provides more information on the power input cable. The trunk box has an internal self-resetting polymer fuse. It can take up to 30 minutes to reset after an overload.

The RibEye's power draw depends on the status of its operating condition, as shown in Table A6.

**Table A6. RibEye power requirements**

Operating Condition	Trunk Box	Controller + LEDs	Total
	Watts		
On/idling	3.3	2	5.3
Acquiring data (typical)	3.3	5	8.3
Maximum*	3.3	9	12.3

\* When all LEDs are out of view of both sensors and driven to full power.

## A.3 Data acquisition and storage

Data is collected to RAM memory and stored post-test in flash memory.

Sample rate: 10,000 samples per second per LED

Acquisition time: 30,000 ms (30 seconds) in RAM, 2 seconds in flash memory

## Appendix B. Cable assemblies

The RibEye is provided with the following cables:

- Controller cable that connects from the trunk box to the RibEye controller
- Power-in cable from the trunk box to an external power source
- Trigger cable for connecting to a trigger source and providing an armed output signal
- LED cables (12), numbered to correspond to the dummy ribs

The Souriau connectors used are crimp pin types, but can also be purchased with solder cups. See your Souriau representative for details.

All Molex Microfit 3.0 connectors are crimp types. The drawings call out the crimp terminals used. We recommend using a Molex crimp tool designed for the Microfit 3 series. The current production hand crimp tool is Molex part number 638190000.

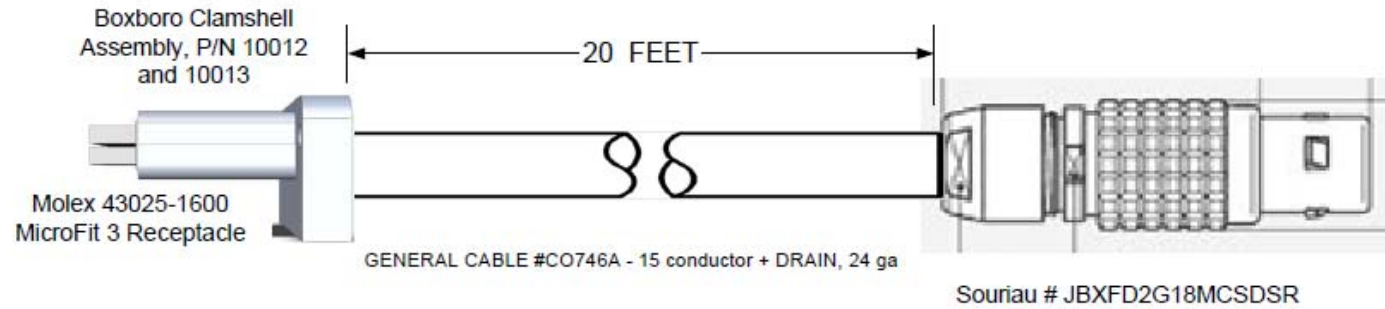
### B.1 Controller cable

Figure B1 shows the controller cable that plugs into the interface/trunk box and the connector that plugs into the RibEye controller. Figures B2 and B3 provide details on the connector and wiring at both ends of the controller cable.

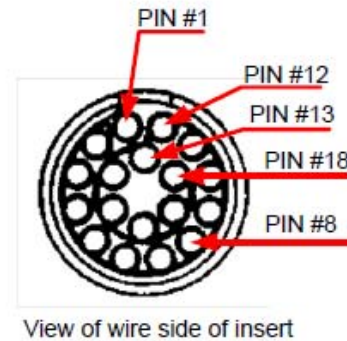
**Figure B1. RibEye controller cable and connector**  
A = Souriau end; B = Microfit end (connector)



**Figure B2. Controller cable, Souriau connector end details**

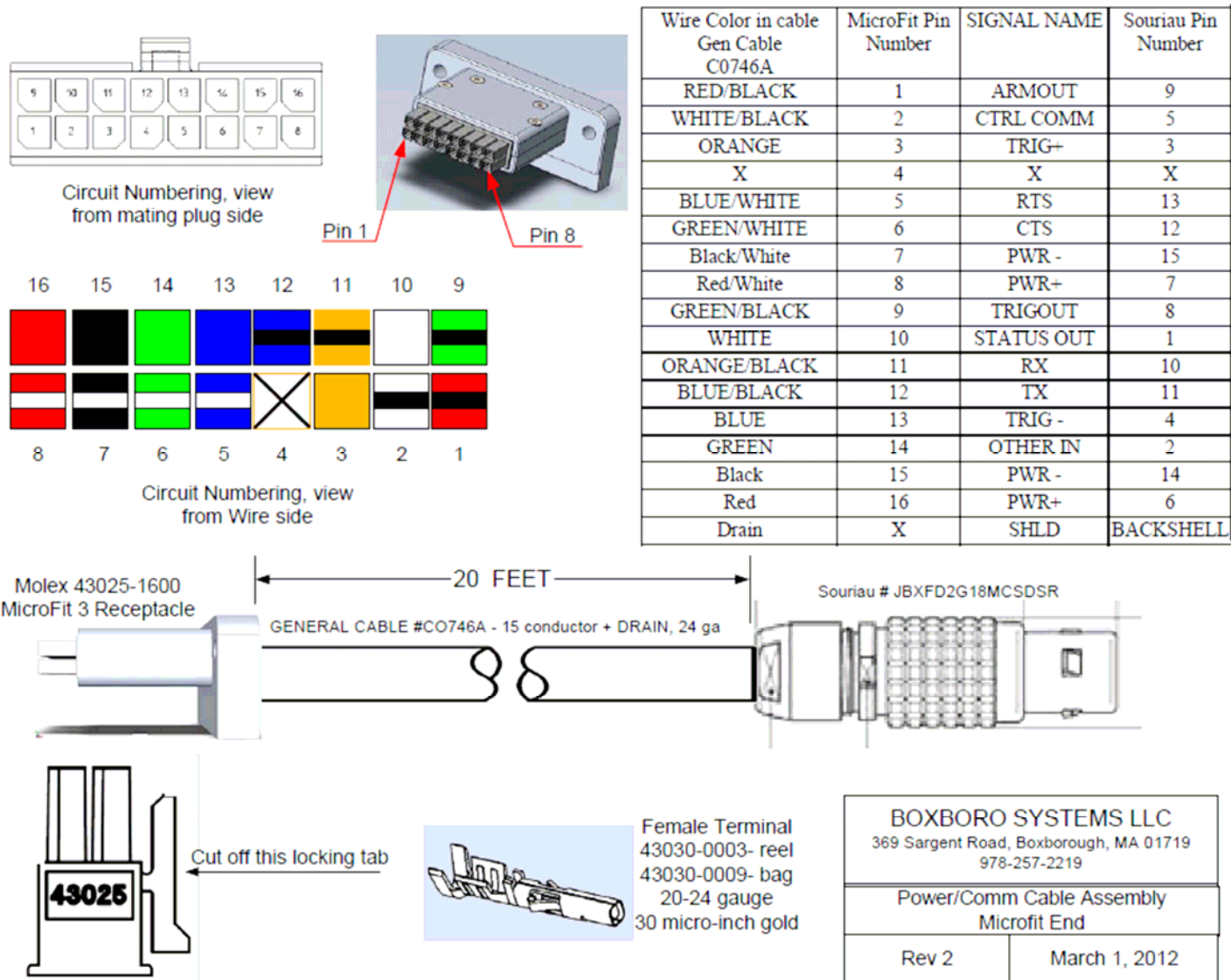


Wire Color in cable Gen Cable C0746A	MicroFit Pin Number	Souriau Pin Number	SIGNAL NAME
Drain	X	BACKSHELL	SHLD
WHITE	10	1	STATUS OUT
GREEN	14	2	OTHER IN
ORANGE	3	3	TRIG+
BLUE	13	4	TRIG -
WHITE/BLACK	2	5	CTRL COMM
Red	16	6	PWR+
Red/White	8	7	PWR+
GREEN/BLACK	9	8	TRIGOUT
RED/BLACK	1	9	ARMOUT
ORANGE/BLACK	11	10	RX
BLUE/BLACK	12	11	TX
GREEN/WHITE	6	12	CTS
BLUE/WHITE	5	13	RTS
Black	15	14	PWR -
Black/White	7	15	PWR -
	X	16	X
	X	17	X
	X	18	X



<b>BOXBORO SYSTEMS LLC</b> 369 Sargent Road, Boxborough, MA 01719 978-257-2219	
Power/Comm Cable Assembly Souriau End Details	
Rev 2	March 1, 2012

**Figure B3. Controller cable, Microfit end details**



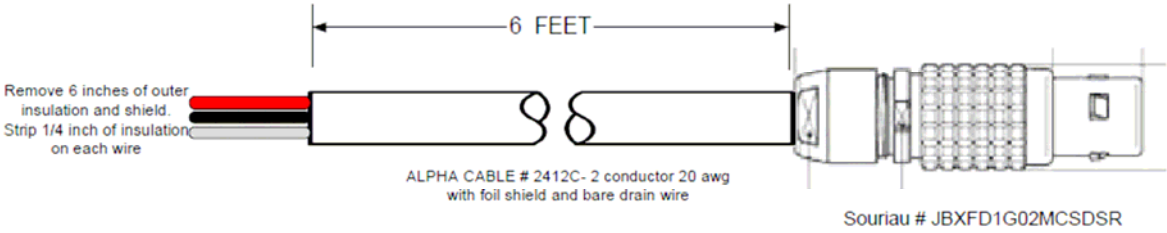
## B.2 Power input cable

The power input cable from the RibEye's interface/trunk box to the power source is terminated at the user end in pigtails. The power cable has two conductors: the red wire (positive) and the black wire (negative/ground), as noted in Appendix A.2, Power requirements. The red wire is connected to the DC power source's positive power connection. The black wire is for the DC power source's negative (ground) connection. Figures B4 and B5 show the power-in cable and the wiring details.

**Figure B4. Power cable from RibEye trunk box**

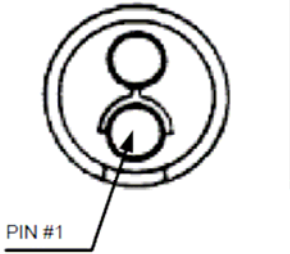


**Figure B5. Power cable details**



Wire Color	Souriau Pin Number
RED	1
BLACK	2
Drain	BODY

View of wire side of insert



<b>BOXBORO SYSTEMS LLC</b> 369 Sargent Road, Boxborough, MA 01719 978-257-2219	
Power In Cable Assembly	
Rev 2	March 1, 2012

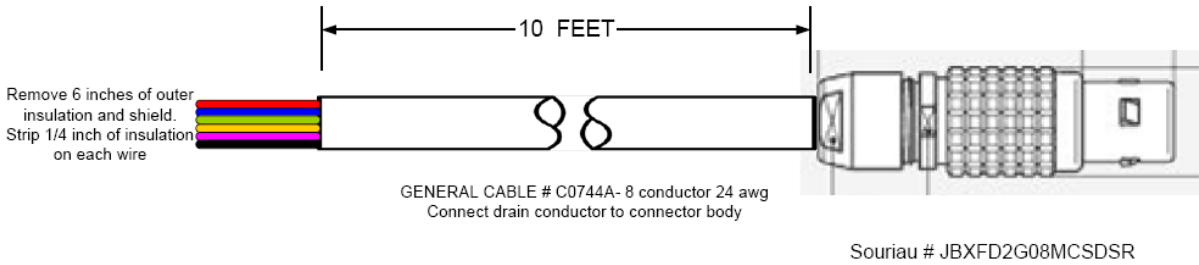
### B.3 Trigger cable

Figures B6 and B7 show the RibEye's trigger cable and details. Appendix C contains more detailed information on the trigger and armed output signals, including wiring options.

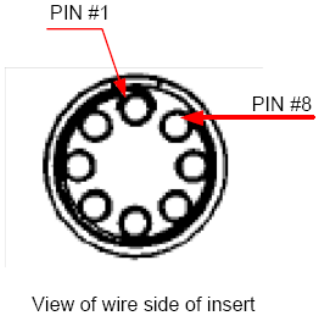
**Figure B6. Trigger cable from RibEye trunk box**



**Figure B7. Trigger cable details**



Wire Color General Cable C0744A	Souriau Pin Number	Signal
RED	1	3.3V PULL-UP
WHITE	2	TRIGGER IN +
GREEN	3	TRIGGER IN -
ORANGE	4	RESERVED
BROWN	5	RESERVED
BLACK	6	GROUND
YELLOW	7	ARMOUT +
BLUE	8	ARMOUT-



<b>BOXBORO SYSTEMS LLC</b> 369 Sargent Road, Boxborough, MA 01719 978-257-2219	
Trigger Cable Assembly	
Rev 2	March 5, 2012

**B.4 LED cables**

Figure B8 and B9 show the RibEye LED cable assemblies. The cable is soldered onto the LED assembly (Figure B10). The LED assembly consists of the LED mounted to a Metal Clad Printed Circuit Board (MCPCB) that acts as a heat sink. Figure B11 shows the details of the LED cable’s Microfit plug end.

**DANGER:** *If you need to re-solder a LED assembly to a new cable, note that the MCPCB will get very hot. You must do the soldering work on a thermal insulator and be aware that the MCPCB will be at the same temperature as the melted solder. Make sure that you do not touch the MCPCB when soldering.*

Replacement LEDs with cables are available from Boxboro Systems. The connector on the LED assemblies (Figure B10) is easily replaceable.

**Figure B8. LED cables (lead wires) attached to connector blocks in RibEye sensor heads (rear spine view)**



**Figure B9. LED cables, connector blocks, and sensor heads (front spine view)**

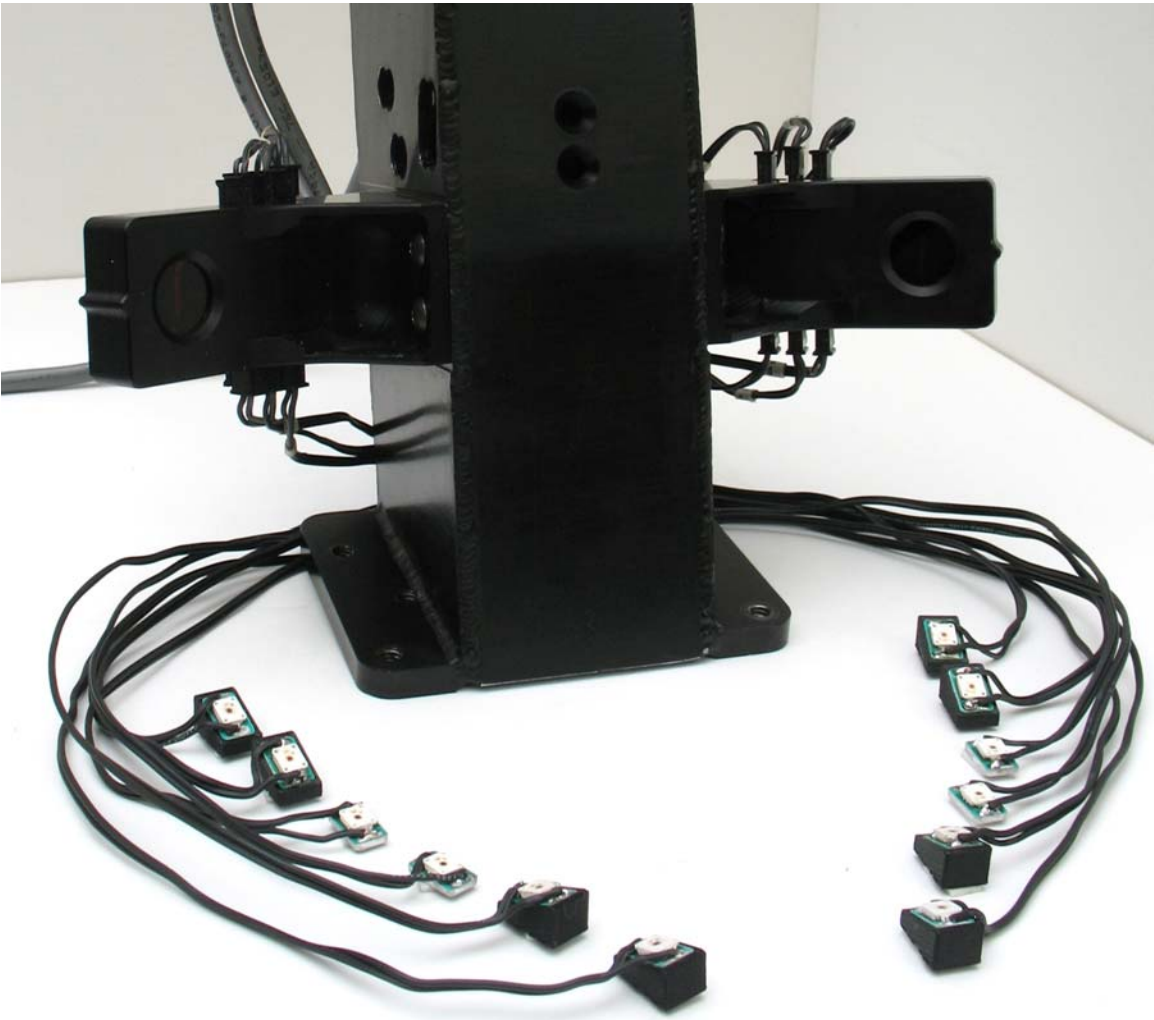


Figure B10. LED cable soldered to LED assembly

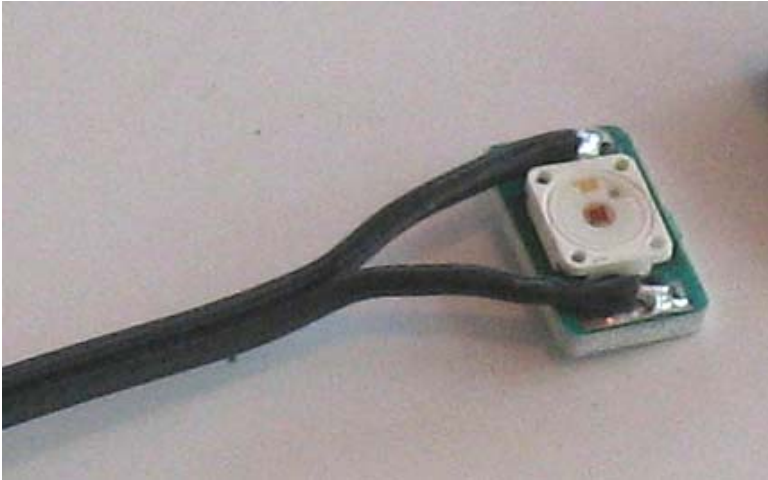
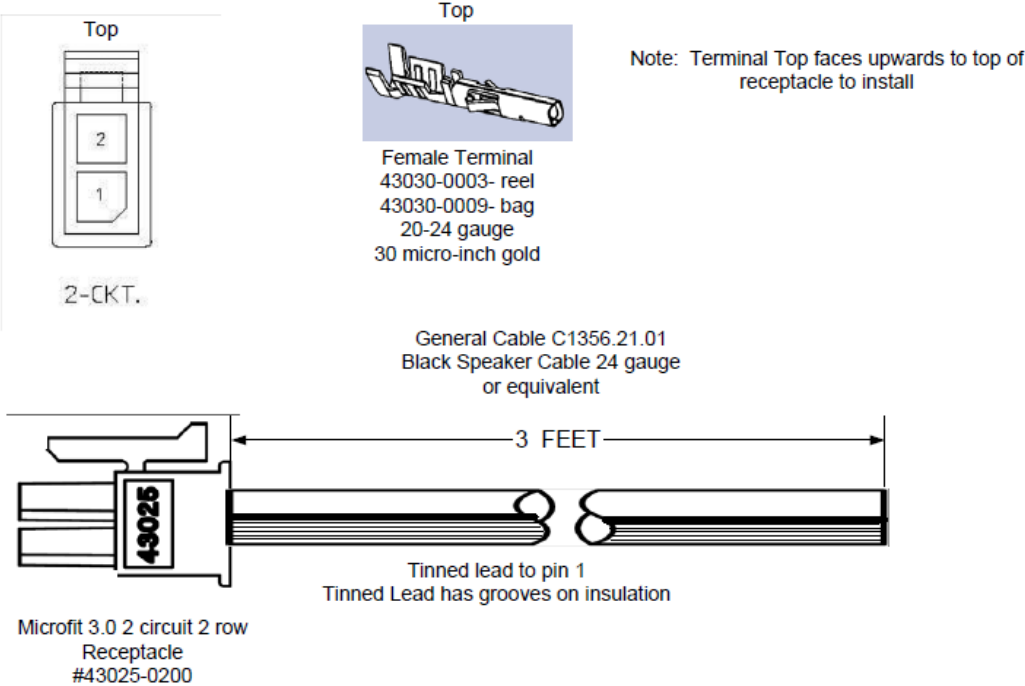


Figure B11. LED cable, Microfit end details



BOXBORO SYSTEMS LLC 369 Sargent Road, Boxborough, MA 01719 978-257-2219	
LED Cable	
Rev 1	November 7, 2011

**Appendix C. Trigger inputs and armed output circuits**

The trigger interface connector on the RibEye’s trunk box is an 8-pin Souriau connector. A mating cable, terminated in a pigtail, is supplied with the RibEye (Figure B6 above). Table C1 lists the pigtail color codes, pin numbers, and signal functions. Figure C1 shows a partial schematic of the interface.

**Table C1. Trigger cable signals**

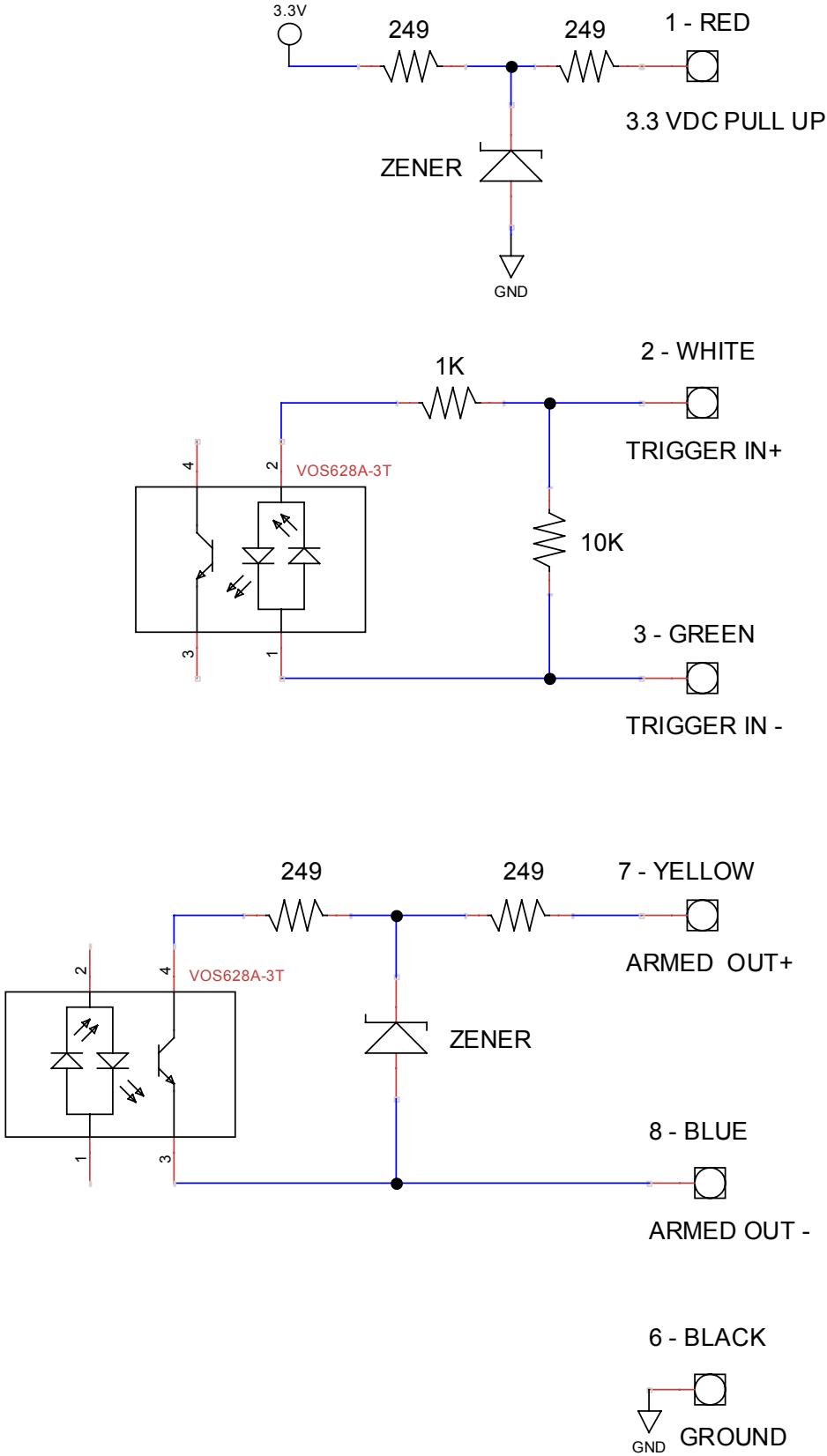
Wire Color (General Cable C0744A)	Souriau Pin Number	Signal
RED	1	3.3V PULL-UP
WHITE	2	TRIGGER IN +
GREEN	3	TRIGGER IN –
ORANGE	4	NOT USED
BROWN	5	NOT USED
BLACK	6	GROUND
YELLOW	7	ARMOUT +
BLUE	8	ARMOUT–

Maximum Ratings:

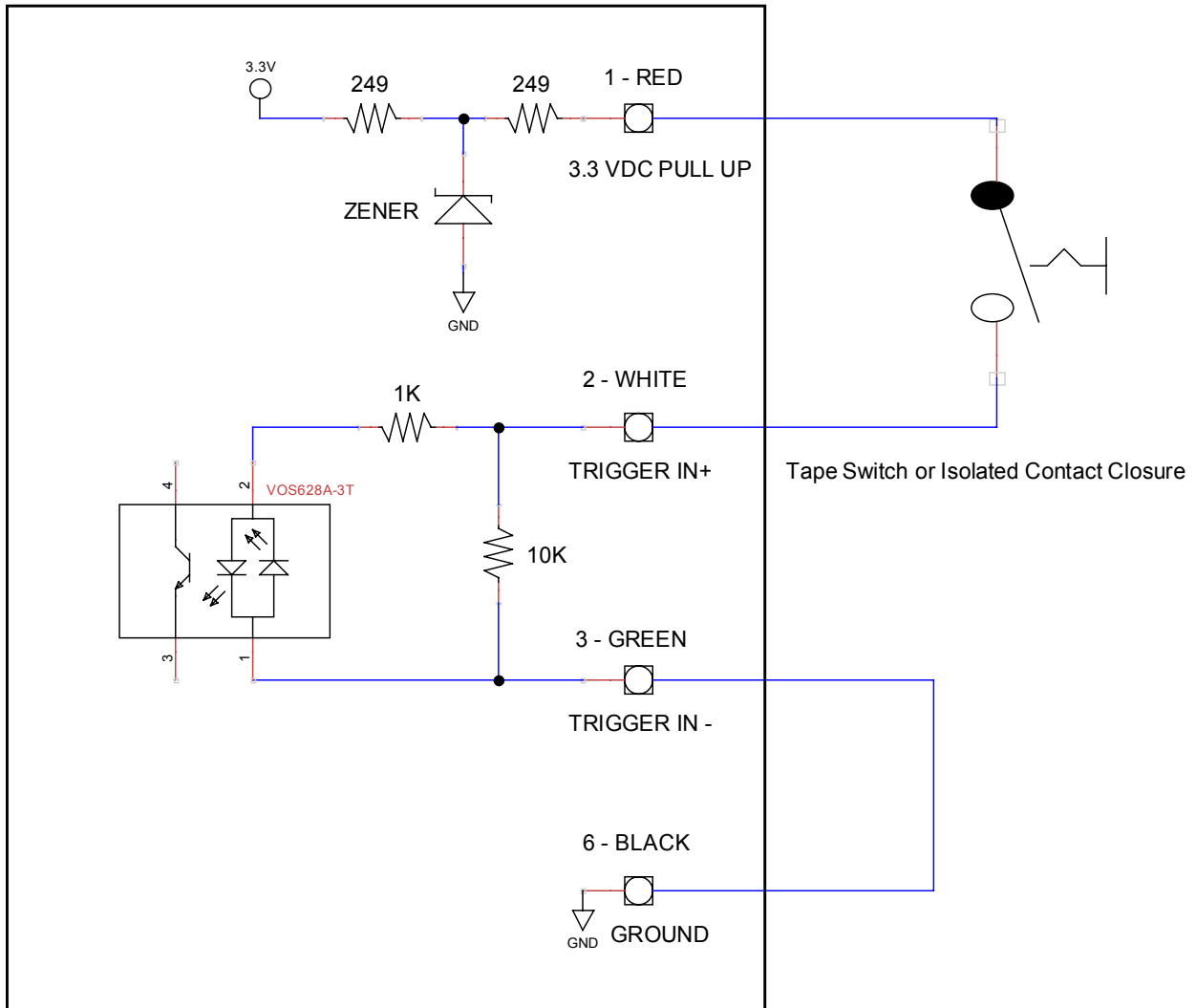
Trigger Input from Trigger + to Trigger – = 15 Volts-DC  
Armed Output from Armed + to Armed – = 15 Volts-DC

Note that the trigger input and armed output are fully isolated. Figures C2–C6 show typical connection diagrams, with notes below each figure.

Figure C1. Partial interface schematic



**Figure C2. Tape switch or isolated contact closure for trigger**



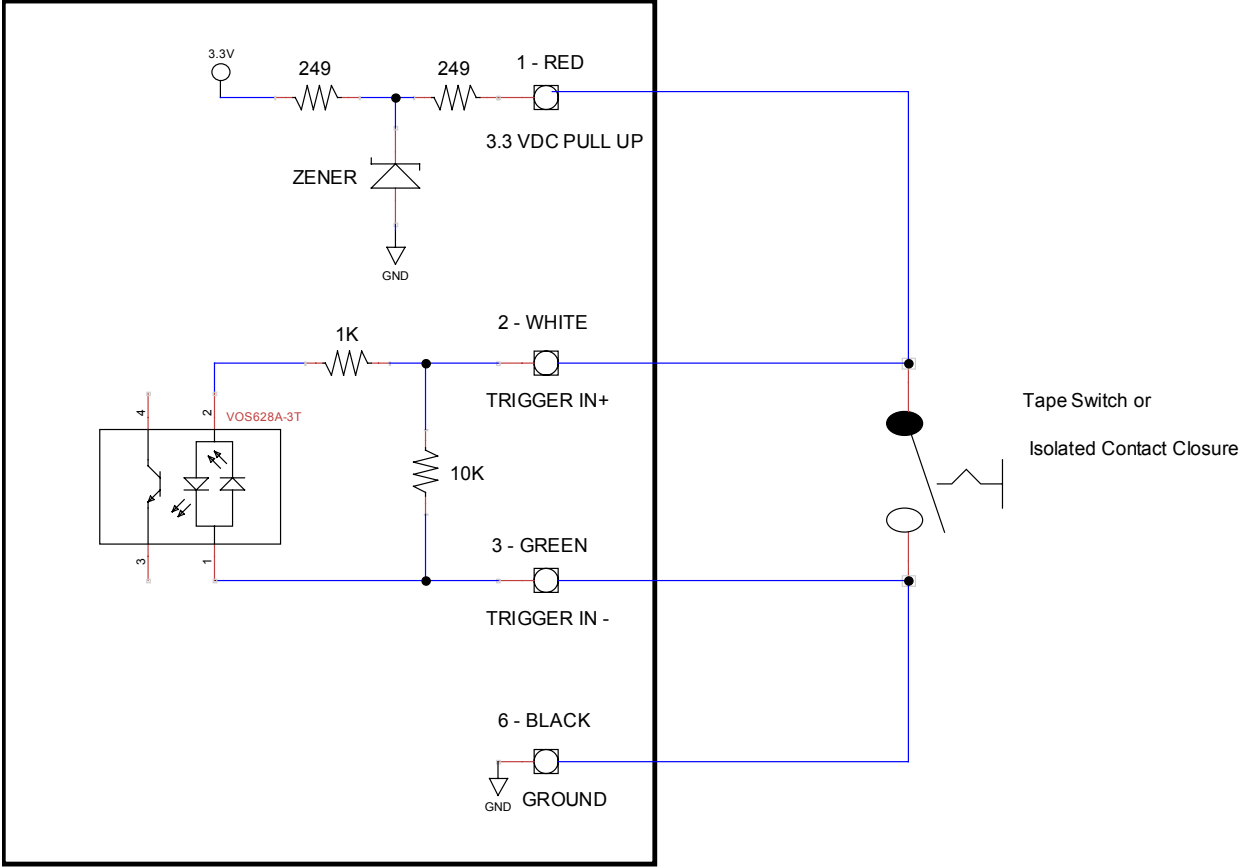
For this connection switch connection option:

If the switch *closes* at the start of the event, select **RISING EDGE** on the RibEye software trigger setting.

If the switch *opens* at the start of the event, select **FALLING EDGE** on the RibEye software trigger setting.

For more information, please refer to the RibEye Software User's Manual, section 2.3, Trigger Setting.

Figure C3. Alternative tape switch or isolated contact closure for trigger



For this connection switch connection option:

If the switch *closes* at the start of the event, select FALLING EDGE on the RibEye software trigger setting.

If the switch *opens* at the start of the event, select RISING EDGE on the RibEye software trigger setting.

Figure C4. Active trigger source

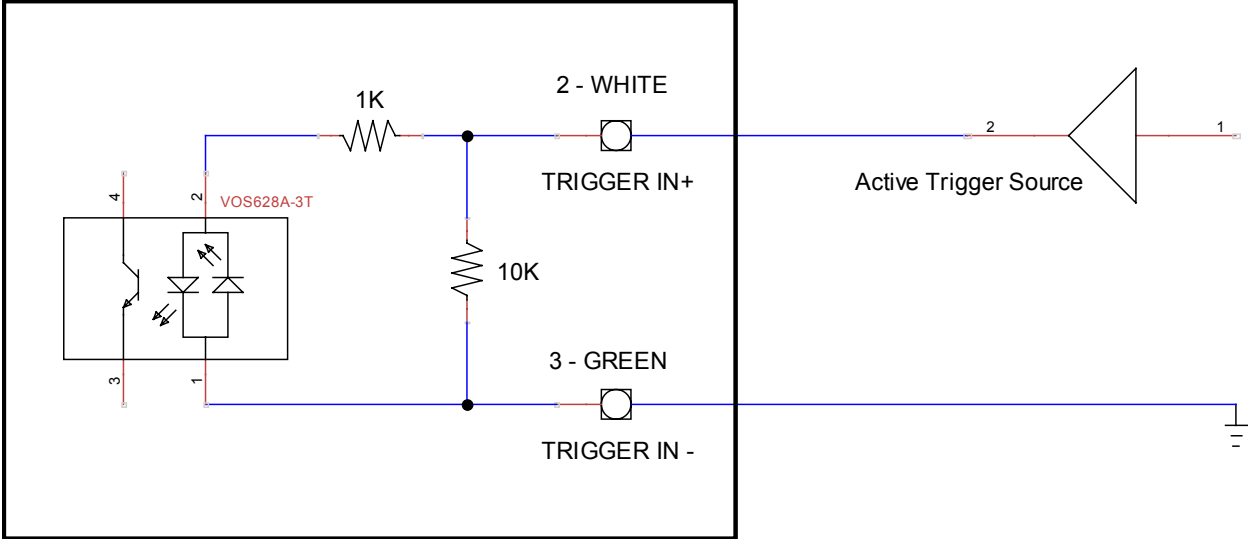
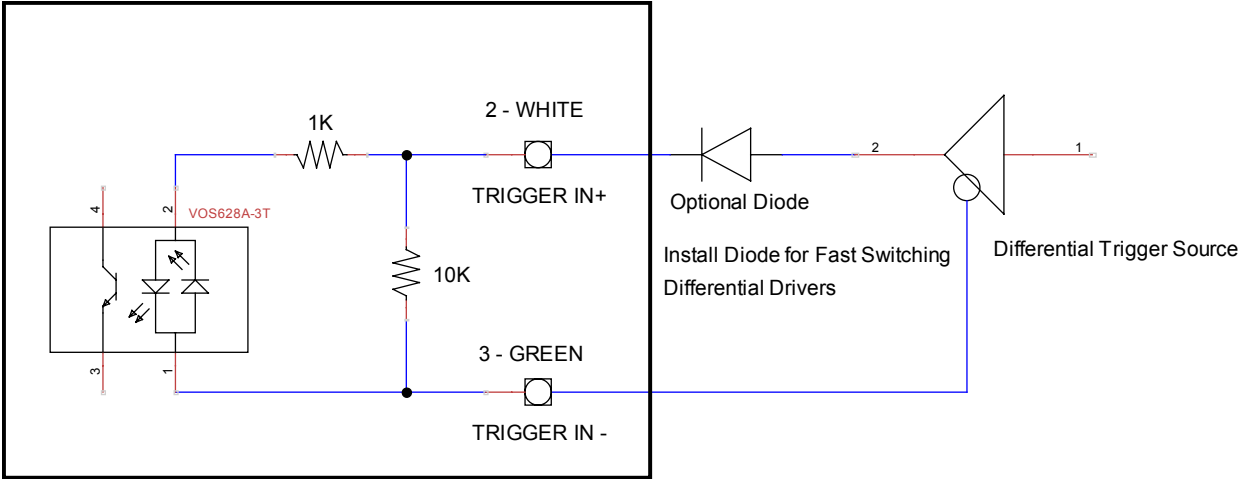
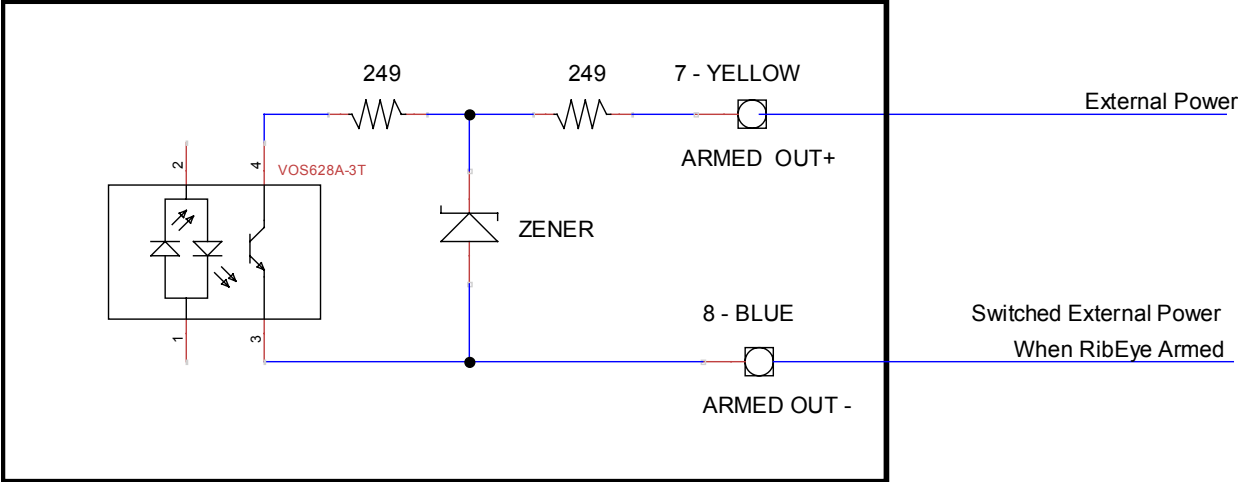


Figure C5. Differential trigger source



For a differential trigger source, you might need to add a small signal diode, such as a 1N914 in series as shown above, if the differential driver transition time is faster than 0.1 milliseconds.

Figure C6. Armed output connection



The armed output can be used to signal other equipment that the RibEye is armed. To maintain isolation, the circuit shown above is configured as an emitter follower, with the collector of the output transistor connected to the external logic power source. The transistor emitter will switch when the RibEye is armed.