

CONNECTING RIBEYE TO DATA ACQUISITION SYSTEMS: WorldSID and Hybrid III RibEyes

To acquire data, the RibEye™ for WorldSID and Hybrid III dummies needs the following power, trigger, and Ethernet connections:

1. Power: 12-36 Volts DC (VDC) or 12-60 VDC with optional DC-DC converter
WorldSID: 20 Watts typical, 40 Watts maximum
Hybrid III: 8.3 Watts typical, 12.3 Watts maximum
2. Trigger signal to mark the time of impact
3. Ethernet for communication between the RibEye controller and the RibEye software.

WorldSID RibEyes

All of the external connections to the WorldSID RibEye controller – power, trigger, and Ethernet – come from the 24-pole “Exit Cable” connector on the lower end of the controller, shown in Figure 1. The dummy exit cable’s 24-pin Microfit plug should be plugged into the exit cable connector and tied to the strain relief saddle with a nylon zip tie.

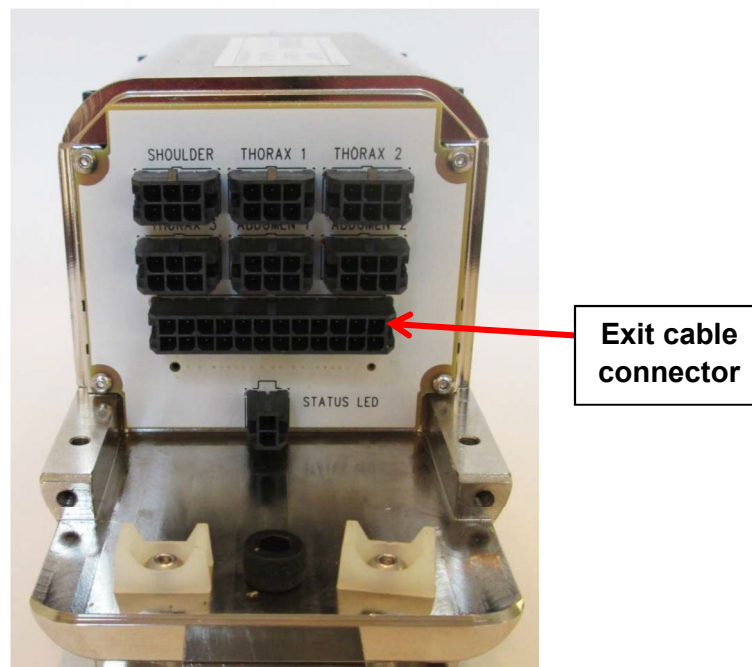

**Figure 1. Exit cable connector
in RibEye controller**

Boxboro Systems provides several cable options to connect the WorldSID RibEye controller to the customer's equipment to get power, trigger, and Ethernet connections (Figures 2–8). You must specify the cable option you need when ordering the RibEye.

For customers with DTS TDAS G5 or Slice in-dummy DAS with external DTS Distributor (see Figure 2)

Exit cable #70011 connects to the RibEye controller at one end and to extension cable #70200 at the other end. This cable set uses the RibEye high-impedance trigger input compatible with the DTS trigger output.

Note: A DTS DBX cable to system port (DDX) – DTS cable #10700-00053 – can be used instead of the #70200 extension cable.

For customers with Kistler NXT32 in-dummy DAS (see Figures 3 and 4)

Exit cable #70020 connects to the RibEye controller at one end and at the other end, to the last NXT32 module in the chain of modules in the dummy. This cable uses the RibEye opto-isolated trigger input compatible with the Kistler CrashLink trigger.

Note: Customers who use CrashLink II with a 48-Volt power supply must use exit cable #70022 and WorldSID RibEye model #60002, which has an internal DC-DC converter.

For customers with other types of internal or external DAS (see Figures 5 and 6)

Separate exit and breakout cables

Exit cable #70025 connects to the RibEye controller at one end and to breakout cable #70201 at the other end. The breakout cable is terminated in pigtails for power, opto-isolated trigger, and an armed output. The Ethernet connection is a standard RJ45 plug for connecting to an Ethernet hub/switch.

Single exit/breakout cable

Exit/breakout cable #70026 connects to the RibEye controller at one end. The other end is terminated in pigtails for power, opto-isolated trigger, and an armed output. The Ethernet connection is a standard RJ45 plug for connecting to an Ethernet hub/switch.

For customers with Kyowa DAS with external DIS-61A Junction Unit (see Figure 7)

Exit cable #70025 connects the RibEye controller at one end to extension cable #70209 at the other end. The extension cable plugs into a Kyowa DIS-61A Junction unit and a separate power pigtail.

For customers with Kistler DTI DAS with External KiHub or KiDau (see Figure 8)

Exit cable #70028 connects the RibEye controller at one end to extension cable #70208 at the other end. The #70208 cable plugs into a KiHub or KiDau. This configuration uses a WorldSID RibEye with a built-in DC-DC converter so that it can accept CrashLink II 48-Volt DC power.

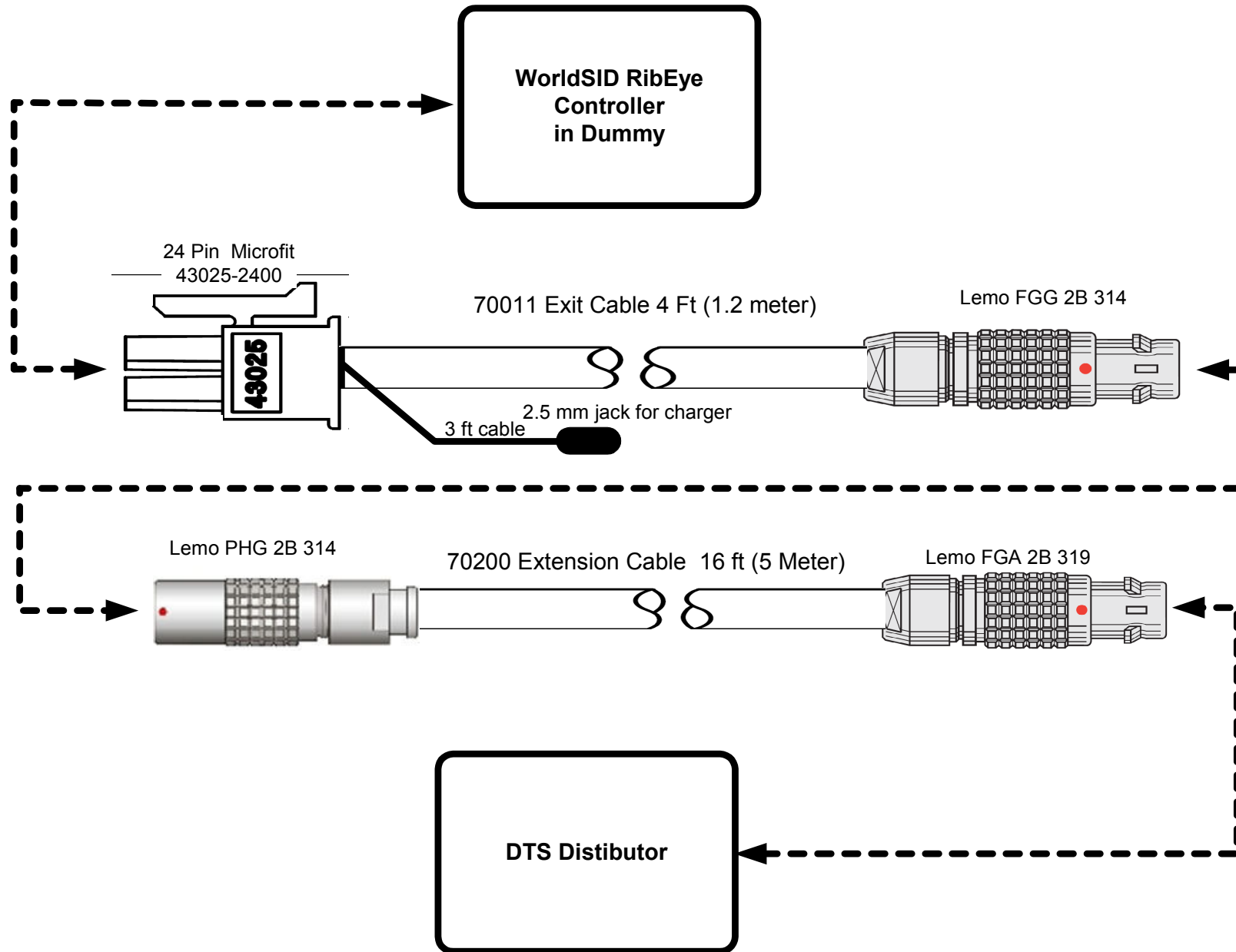

Figure 2. Cable option for DTS DAS – exit cable #70011 and extension cable #70200

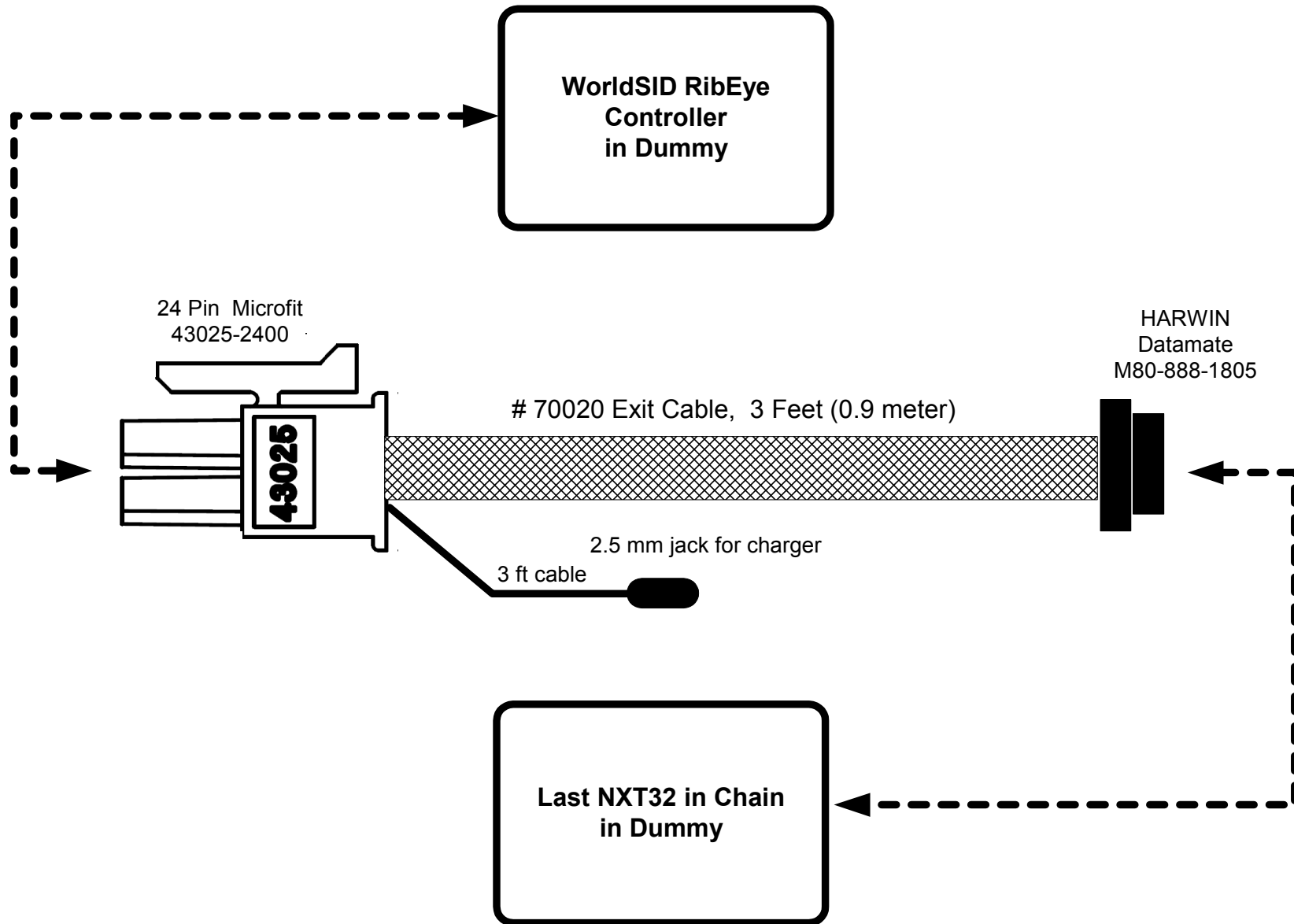

Figure 3. Cable option for Kistler NXT32 DAS – exit cable #70020

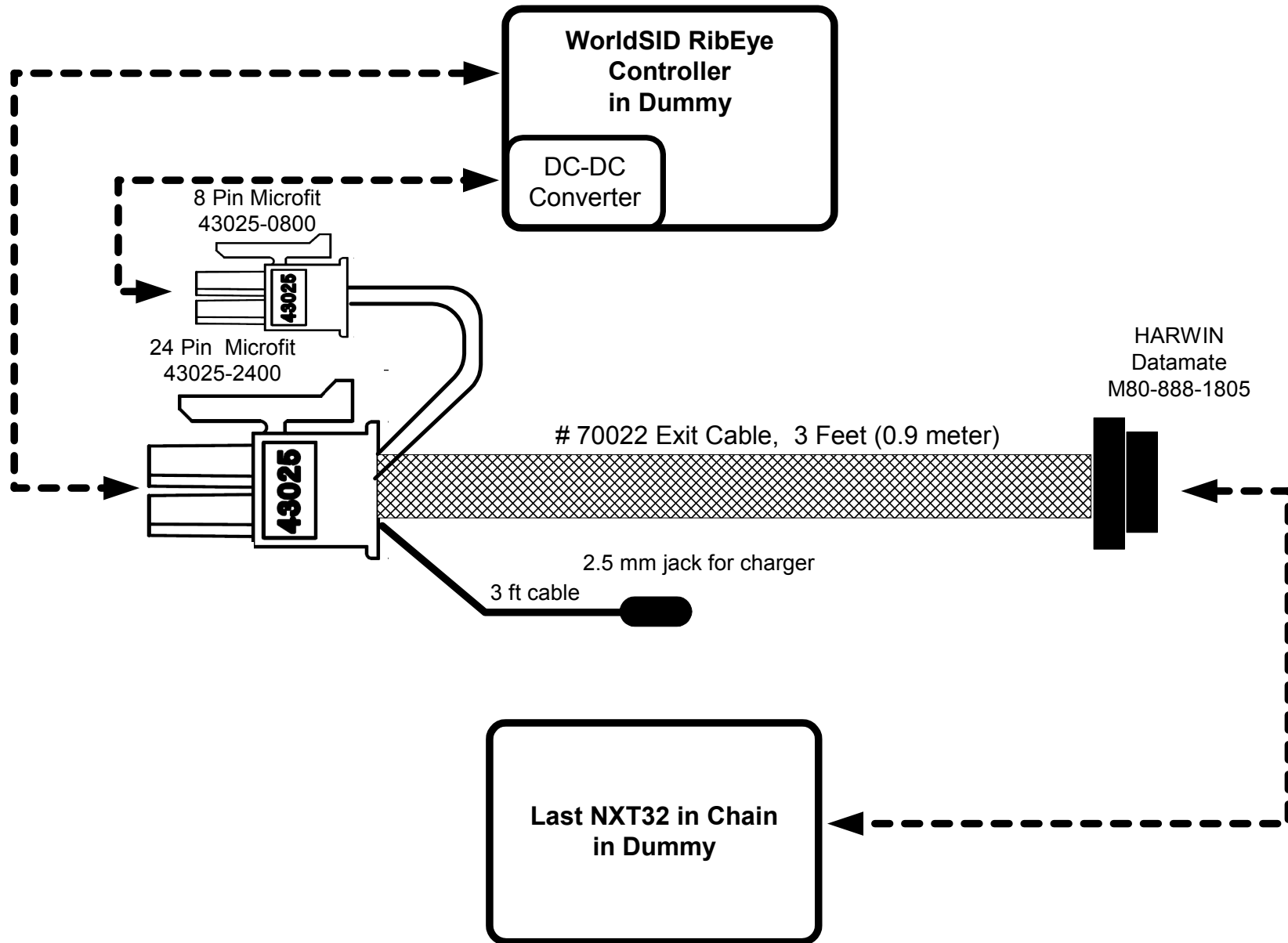

Figure 4. Cable option for Kistler NXT32 DAS with 48-Volt CrashLink II systems – exit cable #70022 and RibEye model #60002 with internal DC-DC converter

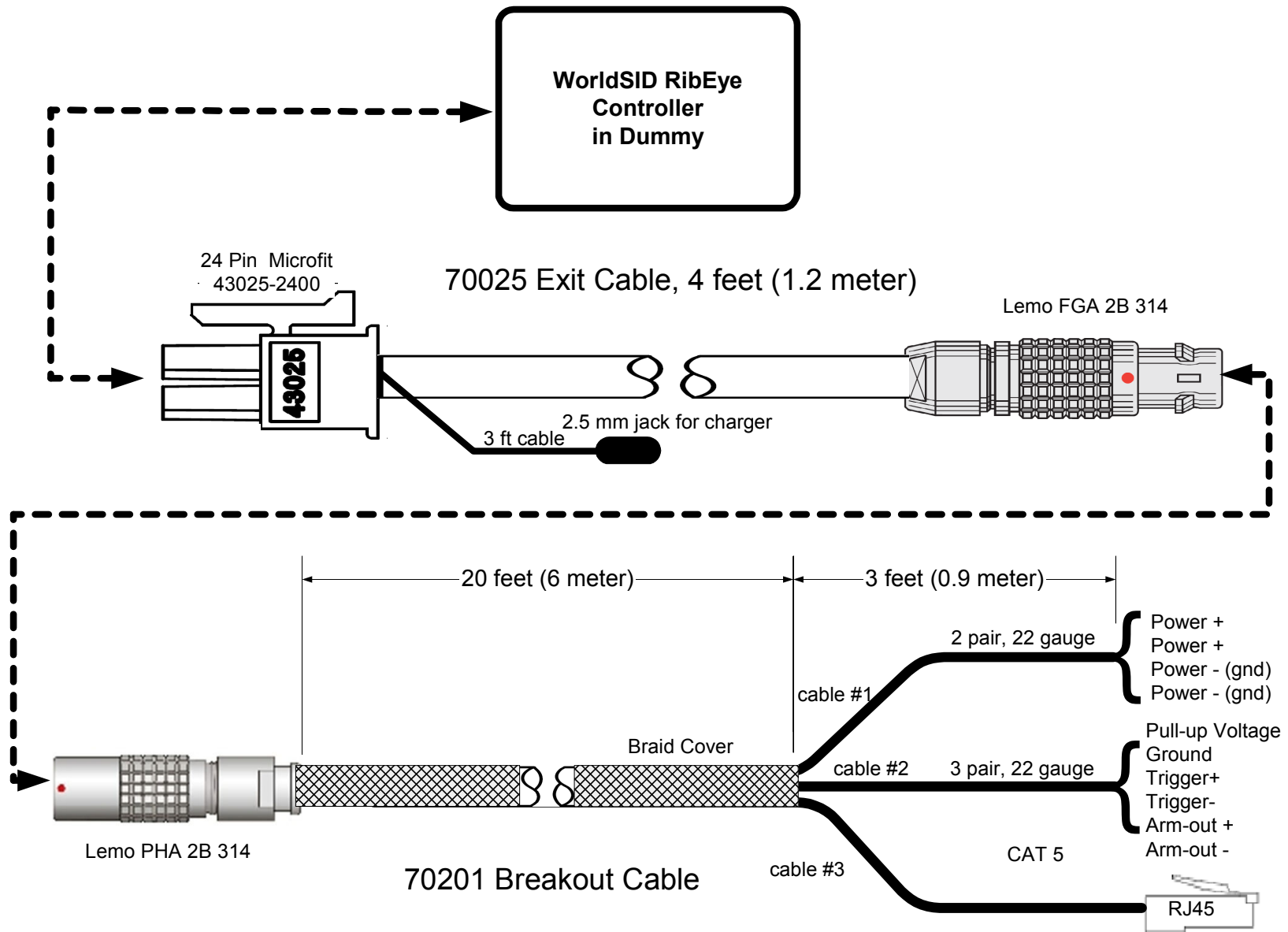

Figure 5. Cable option for generic DAS with separate exit and breakout cables – exit cable #70025 and breakout cable #70201 with opto isolated trigger input and armed output

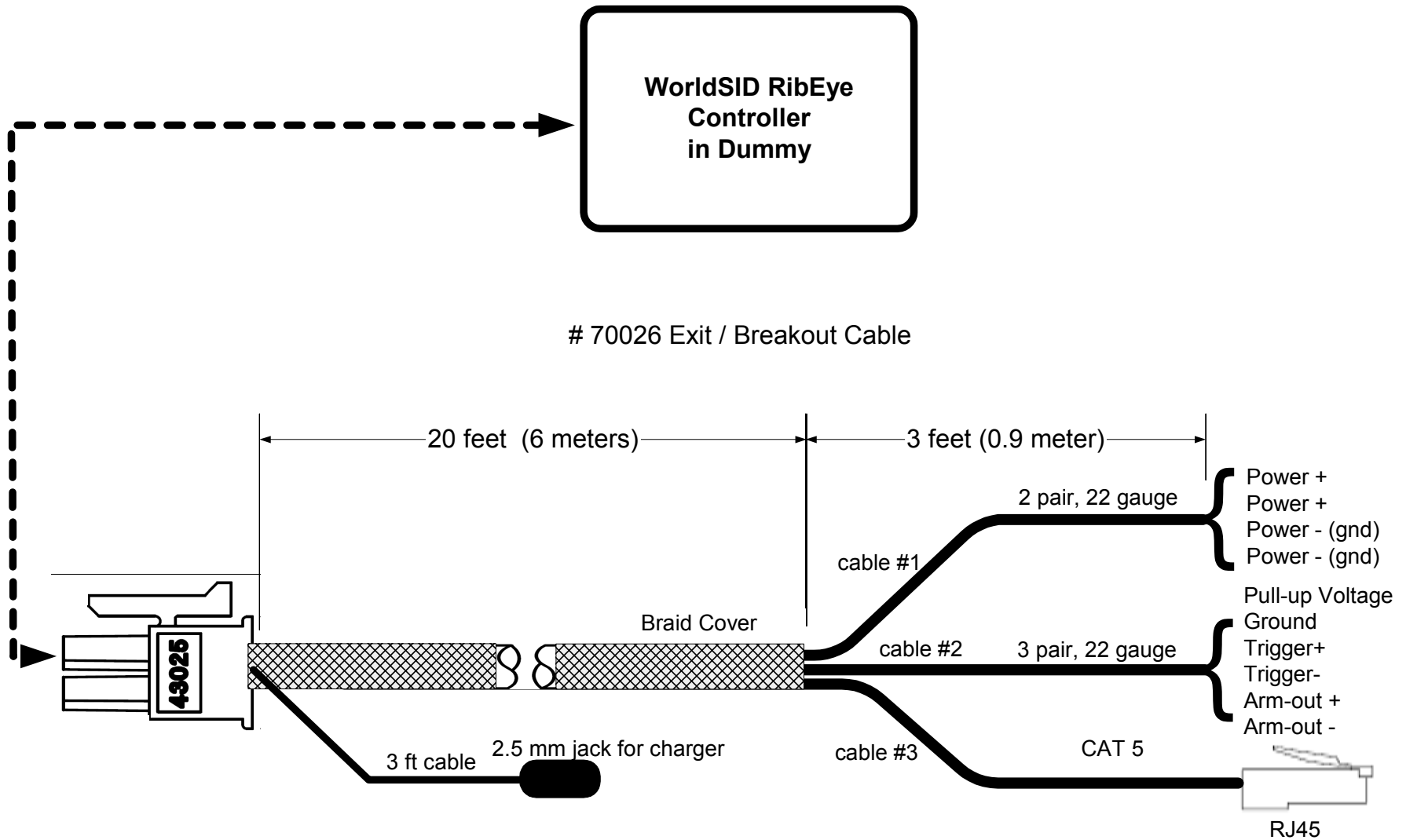

Figure 6. Cable option for generic DAS with single exit/breakout cable #70026 terminating in opto isolated trigger input and armed output

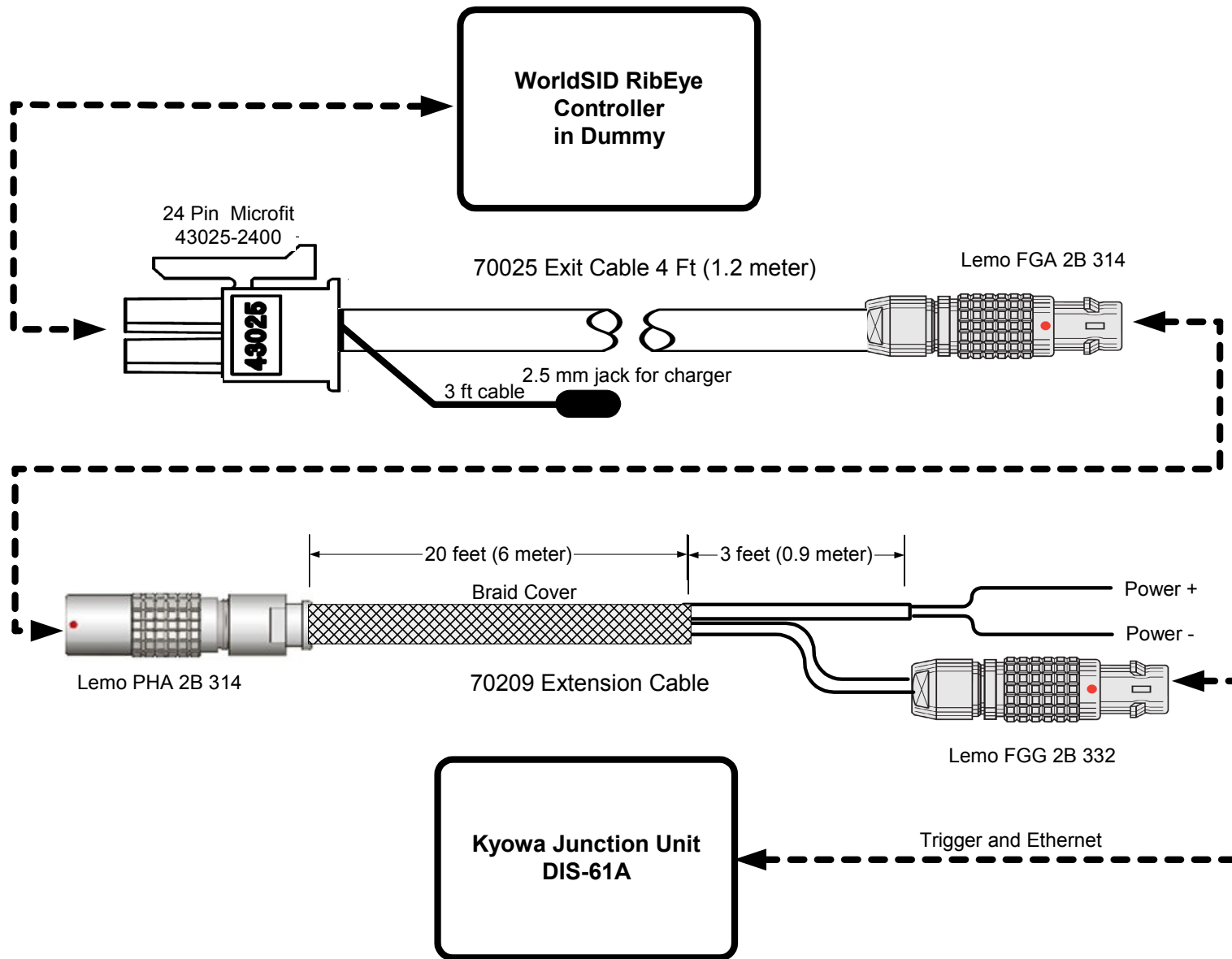

Figure 7. Cable option for Kyowa DAS with separate power supply – exit cable #70025 and extension cable #70209

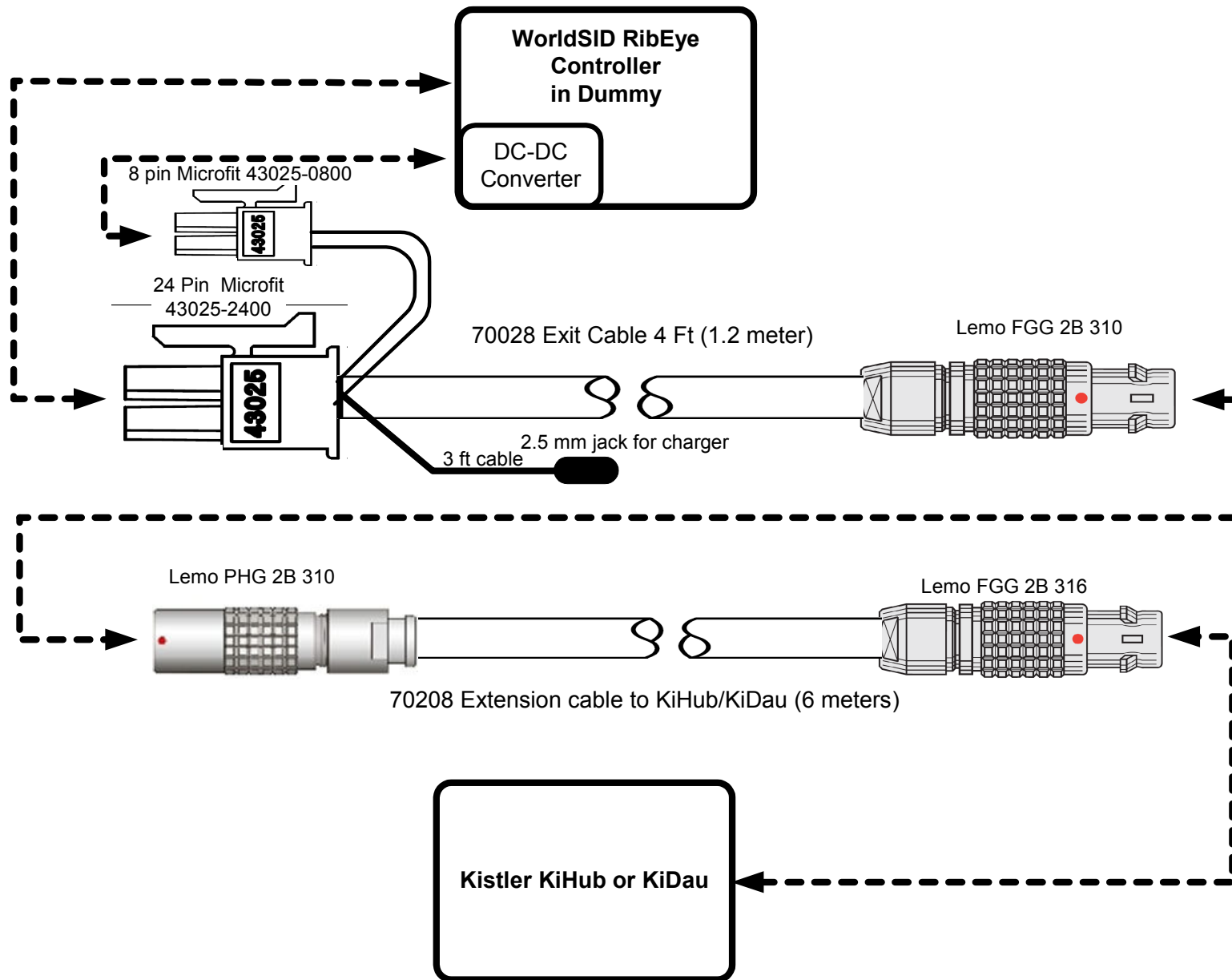

Figure 8. Cable option for Kistler KiHub/KiDau DAS – exit cable #70028 and extension cable #70208

Hybrid III RibEye

RibEyes designed for the Hybrid III dummy come equipped with an external trunk box (Figure 9) that is connected to the RibEye controller inside the dummy. The trunk box and its cables provide the following power, trigger, and Ethernet connections:

1. A 14-pin Lemo plug connects the trunk box to the exit cable coming from the dummy's RibEye controller.
2. A power-in cable with a 2-pin Lemo plug has pigtailed at one end for connecting to a power source.
3. A trigger cable with an 8-pin Lemo plug has pigtailed at one end for connecting to a trigger source.
4. An RJ45 jack on the trunk box accepts a standard Ethernet patch cord (the same as a computer).



Figure 9. RibEye trunk box for Hybrid III dummies

Trigger input

The newest version of the Hybrid III RibEye trunk box (revision 3) accommodates two types of trigger inputs, making it compatible with either DTS or Kistler data acquisition systems:

1. A high-impedance trigger circuit suitable for connection to a DTS trigger signal, such as from a DTS TDAS Pro Mini-Distributor (MDB)
2. A low-impedance optical isolator circuit that can be used with tape switches, Kistler CrashLink RS485-type trigger signals, other types of logic level signals, or an airbag firing circuit.

RibEye users can hook the appropriate signals into their system using the pigtailed trigger and power-in cables provided with the RibEye's trunk box and an Ethernet patch cord.

Accessories

Boxboro Systems can also provide cable assemblies for connecting to data acquisition systems (Figure 10):

- For a DTS MDB, order cable Part #40500, which plugs into one of the four system ports on the MDB. At the other end are plugs for power, trigger, and Ethernet.
- For a Kistler KiDau system, order cable Part #40510, which plugs into the interface-out jack on the last KiDau module in the chain. At the other end are plugs for power, trigger, and Ethernet.

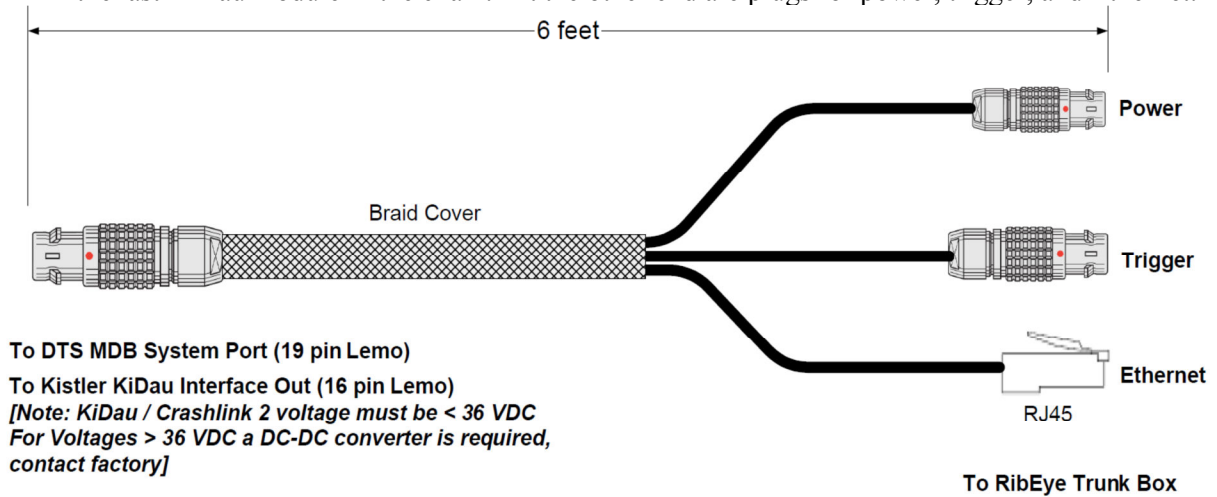

Figure 10. Cable assemblies for connecting Hybrid III RibEye to data acquisition systems